

TRICOLORE BY SEBASTIAN HERKNER  
CATCH LOUNGE BY JAIME HAYON  
FORNELL BY ANDREAS BOZARTH FORNELL  
WORKING TITLE BY HARRI KOSKINEN



# THE COLLECTION

(2017)

 tradition®



# THE COLLECTION

(2017)



---

We strive for timeless designs born  
out of tradition and revolution.  
We honour old masters,  
who were avant-garde in their time  
and welcome new designers  
creating icons of tomorrow.

PALETTE DESK JH9, CATCH CHAIR JH2,  
WORKING TITLE TABLE LAMP HK1





CLOUD SOFA LN3.2, FORMAKAMI JH3 & JH5, PALETTE JH8,  
CATCH LOUNGE JH14, THE MOOR RUG AP6



PALETTE DESK JH9, CATCH CHAIR JH2,  
WORKING TITLE TABLE LAMP HK1

FLOWERPOT VP1, NA STOOL NA3



FLY SOFA SC3, FLY CHAIR SC10, FLY TABLE SC11,  
721 GRAMS IG1, THE MOOR RUG AP6



CLOUD POUF LN4, MEGA BULB SR2



CATCH LOUNGE JH13, MARBLE LIGHT SV6

TRICOLORE SH1-SH3



CATCH CHAIR JH15, UTZON LAMP JU1



IN BETWEEN SK2 & SK5, COPENHAGEN PENDANT SC7,  
721 GRAMS IG1, TRUE COLOURS LP1 & LP5



IN BETWEEN SK1 & SK3, MASS LIGHT NA5





CATCH LOUNGE JH13 & JH14

Jaime Hayon is a Spanish artist / designer with offices in Italy, Spain and Japan. Known for his deep respect for artisan skills, finely-crafted details and a passion for play, Hayon is considered one of the most influential creators of our time, blurring the lines between art, decoration and design. A prolific designer always seeking new horizons, his scope of work extends from furniture, lighting and home accessories to hotel and retail interiors, as well as ceramics, shoes and timepieces.

## CATCH LOUNGE

IN RESPONSE TO THE SUCCESSFUL LAUNCH OF &TRADITION'S CATCH CHAIR BY ACCLAIMED DESIGNER JAIME HAYON, FOLLOWED BY OUR SWIVEL BASED VERSION, WE ARE PLEASED TO INTRODUCE THIS NEWEST MEMBER OF THE SERIES: THE CATCH LOUNGE CHAIR.

BY JAIME HAYON

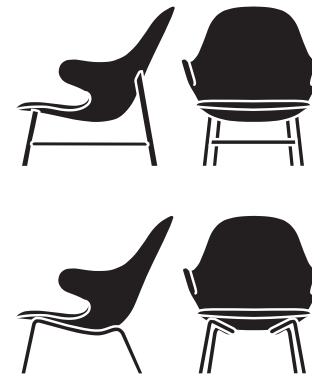

With its outstretched arms like a friend ready to greet you with a warm, welcoming hug, the Catch Lounge Chair builds on Hayon's penchant for humour and personification. At the same time, it introduces a higher back and elongated seat in a singular shell supported by a metal armature. The result is a leisure chair that's angled back just a bit – so you can sit down, relax and, as the name implies - lounge.

“The more we work with Hayon, the more we appreciate his ability to bring humanity and warmth to all his concepts,” says &tradition Brand Manager Martin Kornbek Hansen. “Historically, classic lounge chairs had a somewhat aloof aspect to them. However Hayon has managed to make the Catch Lounge Chair more personal and inclusive, setting the scene for a more intimate atmosphere and conversation. Which coincides with our Danish idea of cosy. Something we call hyggeligt.”

As Hayon sees it, “A lounge chair should be inviting to look at. In a way, it should be almost irresistible. Meaning you can't help but sit back, get comfortable and have a chat. That's what I wanted to achieve. With the added element of the two arms, like a friend, happy to welcome you.”

FLY TABLE SC4, THE MOOR AP6



CATCH LOUNGE JH13





TRICOLORE SH2 – SH3

Sebastian Herkner graduated from the University of Art and Design in Offenbach. Since opening his own studio in 2006, he continues to explore unique possibilities with colour, natural materials and textural effects. Bringing authentic artisan crafts into a contemporary context.

## TRICOLORE

&TRADITION IS PLEASED TO ANNOUNCE  
THE LAUNCH OF THE TRICOLORE VASES

BY SEBASTIAN HERKNER



The Tricolore Vases are a fantastic fusion of colour, ingenuity and artisanry. Each set is comprised of two cylindrical glass vases of different heights, each in a different colour. Pair them together and you have a third colour – hence the name.

“I’m passionate about colour, real materials and working with artisans,” explains German designer Sebastian Herkner. “With the Tricolore Vases, I played with a spectrum of colours, gauging which third colour would appear when the two colours overlap. How the colours would interact with sunlight. And fine-tuning the density of the glass to get just the right nuance. There are three sets of two vases, each in a different colour, height and diameter. Just like I experimented with the choice of colours, people can play with colour, too. They can place any of the individual vases wherever they need a little colour in their life.”

Craftsmanship played a key role in achieving a personal sense of perfection. As Herkner sees it, knowledge of artisan crafts is passed on from one generation to the next, but too often they are destined to disappear. “Each vase passed through many expert artisan hands in the process of creation. Using wooden moulds is very tricky for glass blowers. It’s a challenge to get the sharpness and the precise 90-degree edge on top. Then there’s the process of cutting, sanding and polishing. We used an old fashioned technique to hand blow each vase. The hand craftsmanship makes it more beautiful and more human.”

“It’s all about the communication of colour,” says &tradition Brand Manager Martin Kornbek Hansen. “From Herkner’s choice of colours, the third colour created by two vases together, the interplay of light and the glass itself... Colours have such a positive effect on our emotions and sense of wellbeing. At &tradition, we continue to bring colour into our portfolio of products – and the lives of the people who bring them into their homes.”

As for the design itself, the look is contemporary yet timeless. Here Herkner wanted something simple, straight and sophisticated, with the intention of adding colour to any interior – not clutter. “I reduced the design to the maximum, making each vase like a column. Very classic. Working with glass is ideal, because it allows for the light and reflections to enhance the beauty even more.”

The Tricolore Vases are designed to stand alone, to be clustered together and, of course, to add an extra dimension of colour when two are paired together. What makes them even more appealing is the handcraftsmanship involved in the creation of each one. “Tradition tied to innovation is at the core of everything we do,” adds Hansen. “Herkner’s approach encompasses a concept that runs deep in our DNA. He does it with simplicity and a touch of panache.”



FORNELL ABF1

Andreas Bozarth Fornell is a Stockholm-based architect with a background in designing intriguing interiors for fashion brands like Acne around the world. Fornell is enthralled with the idea of art and ambiance. Keen on experimenting with the innate properties of materials to create concepts that are relevant and riveting.

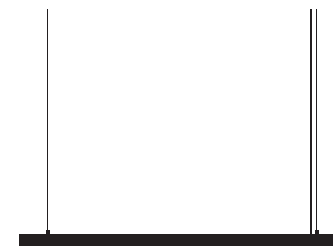

## FORNELL

&TRADITION IS PLEASED TO ANNOUNCE  
THE LAUNCH OF THE FORNELL LAMP

BY ANDREAS BOZARTH FORNELL

**Fornell ABF1 pushes the creative envelope in a simple, streamlined lamp that does more than illuminate. It ventures into the art of atmosphere.**

Inspiration can come from anywhere and anything – even contradictions. For Swedish architect Andreas Bozarth Fornell, his work creating the boutique interiors for the Acne fashion brand influenced his desire to design a lamp that added to the ambience without stealing the limelight. At the same time, artist Donald Judd, a forerunner of the Minimalist movement, inspired Fornell's desire to create a functional object without any intentions beyond its physical presence.

The departure point for Fornell ABF1 was functionality. "I started with a long LED bulb and the classic U shape," explains Fornell. "But the light emitted was very narrow. So I angled the edges to have wings in order to disperse the light. I love exploring the inherent qualities of materials. Aluminium is a bit industrial and I wanted to make it look elegant but understated. So I played with a matt surface on the outside of the lamp and a high polished, mirrored effect on the inside."

While the fashion world is focused on fleeting trends, the intention behind Fornell ABF1 was to design something that would never go out of fashion. Something timeless. "I don't believe in design for the sake of design," admits Fornell. "I prefer objects that you really need in your life. Of course, it's not enough to need them. I try to design objects that you enjoy having around. Something you want to share your space with."

Naturally, growing up in Scandinavia is also an influence on Fornell's sense of aesthetics. The stark landscape and snowy winters, with darkness starting to descend in the afternoon. All these elements operate on a subconscious level. "It's no wonder the Nordic countries are famous for their lamps," says &tradition Brand Manager Martin Kornbek Hansen. "Still, the simplicity, functionality and Fornell's inventive use of materials and effects are qualities very appealing around the world. They're the essence of what we look for in a design."

Available in white, black or brass, Fornell ABF1 is linear, light and alluring. A compelling pendant lamp designed with a low profile in mind.



IN BETWEEN SK1 & SK4



CATCH CHAIR JH15



MAYOR SOFA AJ5



WORKING TITLE TABLE LAMP HK1

Harri Koskinen is an award-winning Finnish designer who initially made a name for himself with his Block Lamp, part of MoMa's permanent design collection in New York. His manifesto is all about making everyday life more enjoyable. Solving problems with simple, sparse and efficient solutions that are equally pleasing to the eye.



## WORKING TITLE

&TRADITION IS PLEASED TO ANNOUNCE  
THE LAUNCH OF THE WORKING TITLE TABLE LAMP

BY HARRI KOSKINEN

The Working Title Table Lamp is the epitome of a table lamp. An elegant expression of a classic design archetype in brushed aluminium. Finessed with an added functionality – a dimmer button to let you set the mood or focus fully on the object of your attention.

For designer Harri Koskinen, it was the ideal brief. Design the ultimate table lamps of table lamps. Something that would work at home and at the same time, feel at home at work. Given Koskinen's natural proclivity for simple shapes driven by functionality, the challenge involved creating the most convenience with the least amount of extraneous elements.

"I always try to achieve simplicity and universality," says Koskinen. "Quality pieces made with honest materials that could fit into any setting, any culture."

With the Working Title Table Lamp, Koskinen started with the idea of a small sculpture for a table. There were three basic components: a base, a stem and a shade. The question was how to create a harmonious composition with all the elements together as an entity? "To tie it all together I chose a monochromatic material solution: brushed aluminium. It makes the lamp more elegant. The smooth surface is pleasing to the eye and to the touch. The circular shape of the base is reflected in the shape of the shade, with a flexible, swivel stem connecting the two."

In an ever-changing urban lifestyle, how do you address the different types of lighting needed for different spaces? As Koskinen sees it, "The world is in transition. The spaces where we live and work are more fluid than fixed. I wanted a multi-functional lamp for any type of hybrid space. Also in terms of the lighting itself. I added a dimmer function to the design so people can use it to focus on work or to create a nice atmosphere by their bedside. The light source is LED, using the latest energy-efficient technology."

For &tradition Brand Manager Martin Kornbek Hansen, the solution is iconic. "We always look for a timeless design with a simple aesthetic. Something classic yet contemporary. Koskinen surpassed our expectations with this beautiful composition of elements that come together like a sculpture. The brushed aluminium makes it subtle and sophisticated. Add to that a dimmer – unique to typical table lamps – and you have the ultimate embodiment of convenience in a chic little solution."



FLY SOFA SC3



COPENHAGEN PENDANT SC7



## The Designers

All The Way To Paris  
 Andreas Bozarth Fornell  
 Arne Jacobsen  
 Benjamin Hubert  
 Flemming Lassen  
 Harri Koskinen  
 Isabell Gatzen  
 Jaime Hayon  
 Jørn Utzon  
 Lex Pott  
 Luca Nichetto  
 Mia Hamborg  
 Norm Architects  
 Ontwerpduo  
 Sami Kallio  
 Samuel Wilkinson  
 Sebastian Herkner  
 Sofie Refer  
 Space Copenhagen  
 Studio Vit  
 Verner Panton  
 Victor Vetterlein

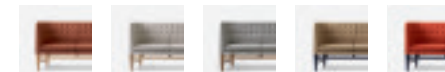
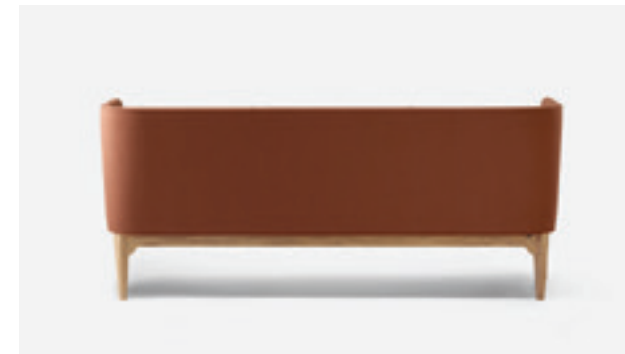
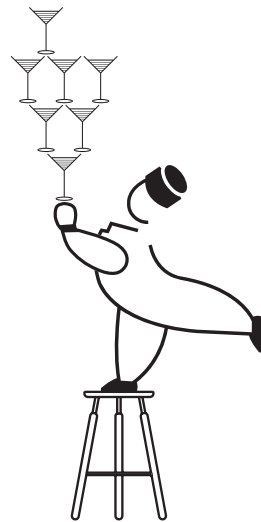

## MAYOR SOFA AJ5

BY ARNE JACOBSEN & FLEMMING LASSEN  
 1939

**Product category** Sofa  
**Materials** Solid oak base, solid beech frame, CMHR foam, fabric or leather upholstery.  
**Dimensions (cm/in)** H: 82cm/32.3in, D: 62cm/24.4in, L: 200cm/78.7in, Seat height: 40cm/15.7in.  
**Stock items** White oiled oak with Hallingdal 130  
**6 wks. lead-time** All fabrics, leathers and COM available with white oiled, smoked oiled or black stained solid oak base.

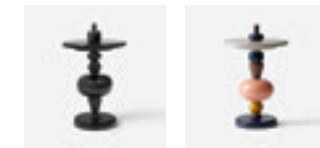
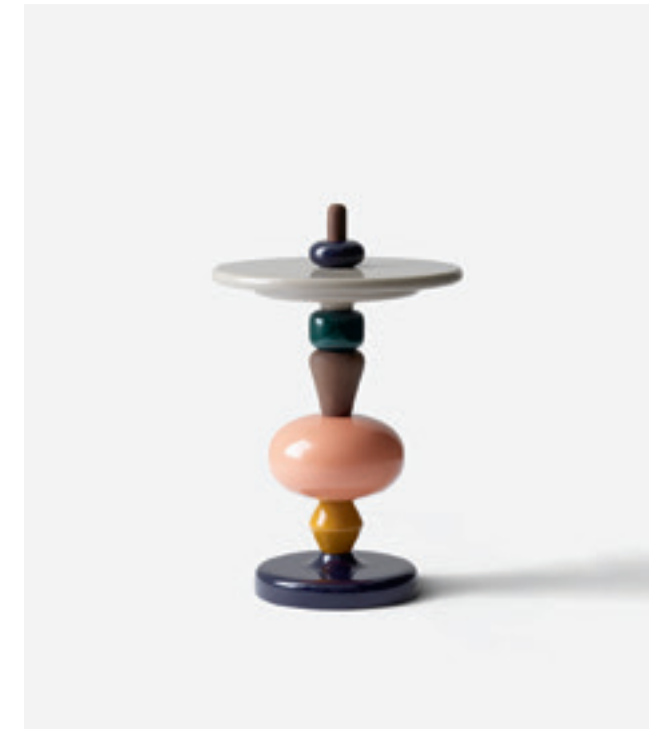
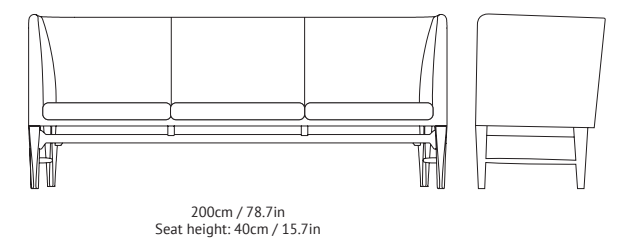

## SHUFFLE TABLE MH1

BY MIA HAMBORG  
 BLACK EDITION BY PETER HAGEN  
 2010

**Product category** Side table  
**Materials** PU Lacquered MDF, polished marble, PU lacquered solid beech, solid oiled oak.  
**Dimensions (cm/in)** Ø: 45cm/17.7in, H: 69cm/27.2in.  
**Colours** Black lacquered wood and polished Nero Marquina marble or Spectrum.

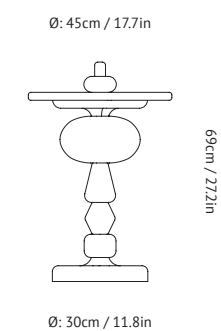

Ø: 30cm / 11.8in



## CLOUD TWO SEATER LN2

BY LUCA NICHETTO  
2015

**Product category** Sofa  
**Materials** Structure in wood and metal with no-zag springs. CMHR foam, Comforell and feather pillows. Solid steel legs. Fabric or leather upholstery.  
**Dimensions (cm/in)** H: 75cm/29.5in, D: 84cm/33in, L: 168cm/66in, Seat height: 40cm/15.7in.  
**8 wks. lead-time** All fabrics, leathers and COM available with chromed, bronzed or warm black powder coated legs.

## CLOUD THREE SEATER LN3.2

BY LUCA NICHETTO  
2015

**Product category** Sofa  
**Materials** Structure in wood and metal with no-zag springs. CMHR foam, Comforell and feather pillows. Solid steel legs. Fabric or leather upholstery.  
**Dimensions (cm/in)** H: 75cm/29.5in, D: 84cm/33in, L: 220cm/86.5in, Seat height: 40cm/15.7in.  
**8 wks. lead-time** All fabrics, leathers and COM available with chromed, bronzed or warm black powder coated legs.

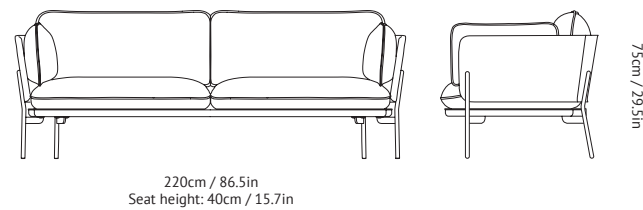
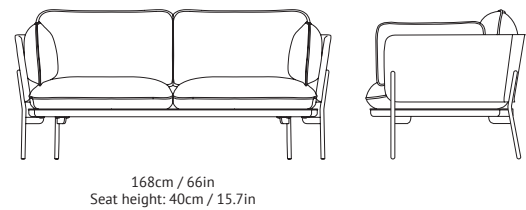

## CLOUD ONE SEATER LN1

BY LUCA NICHETTO  
2015

**Product category** Lounge chair  
**Materials** Structure in wood and metal with no-zag springs. CMHR foam, Comforell and feather pillows. Solid steel legs. Fabric or leather upholstery.  
**Dimensions (cm/in)** H: 75cm/29.5in, D: 84cm/33in, L: 100cm/39.3in, Seat height: 40cm/15.7in.  
**8 wks. lead-time** All fabrics, leathers and COM available with chromed, bronzed or warm black powder coated legs.

## CLOUD POUF LN4

BY LUCA NICHETTO  
2015

**Product category** Pouf  
**Materials** Structure in wood and metal with no-zag springs. CMHR foam, Comforell and feather pillows. Solid steel legs. Fabric or leather upholstery.  
**Dimensions (cm/in)** H: 40cm/15.7in, D: 72cm/28.3in, L: 78cm/30.7in, Seat height: 40cm/15.7in.  
**8 wks. lead-time** All fabrics, leathers and COM available with chromed, bronzed or warm black powder coated legs.

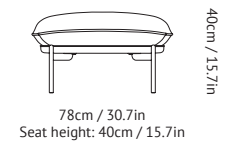
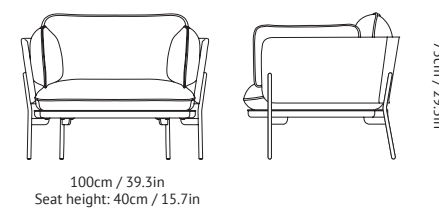



## FLY CHAIR SC10

BY SPACE COPENHAGEN  
2017

**Product category** Lounge chair  
**Materials** Oak frame and base. CMHR foam and feather pillows. Fabric upholstery.  
**Dimensions (cm/in)** H: 70cm/27.6in, W: 77cm/30.3in, D: 74cm/29.1in, Seat height: 40cm/15.7in.  
**Stock items** White oiled oak/Chivasso Hot Madison (CH1249/094), Smoked oiled oak/Chivasso Hot Madison (CH1249/093), Smoked oiled oak/Harald 182.  
**6 wks. lead-time** All other fabrics, leathers and COM available with white oiled or smoked oiled oak base and frame.

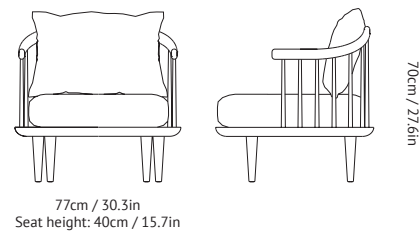

## FLY CHAIR SC1

BY SPACE COPENHAGEN  
2013

**Product category** Lounge chair  
**Materials** Oak frame and base. CMHR foam and feather pillows. Fabric upholstery.  
**Dimensions (cm/in)** H: 70cm/27.6in, D: 80cm/31.5in, L: 87cm/34.3in, Seat height: 40cm/15.7in.  
**Stock items** White oiled oak/Chivasso Hot Madison (CH1249/094), Smoked oiled oak/Chivasso Hot Madison (CH1249/093), Smoked oiled oak/Harald 182.  
**6 wks. lead-time** All other fabrics, leathers and COM available with white oiled or smoked oiled oak base and frame.

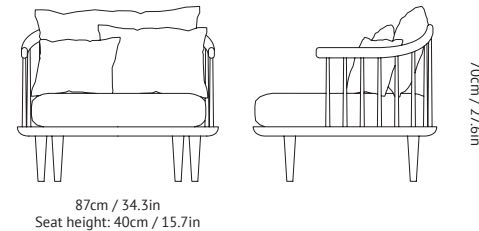

## FLY SOFA SC2

BY SPACE COPENHAGEN  
2013

**Product category** Sofa  
**Materials** Oak frame and base. CMHR foam and feather pillows. Fabric upholstery.  
**Dimensions (cm/in)** H: 70cm/27.6in, D: 80cm/31.5in, L: 162cm/63.8in, Seat height: 40cm/15.7in.  
**Stock items** White oiled oak/Chivasso Hot Madison (CH1249/094), Smoked oiled oak/Chivasso Hot Madison (CH1249/093), Smoked oiled oak/Harald 182.  
**6 wks. lead-time** All other fabrics, leathers and COM available with white oiled or smoked oiled oak base and frame.

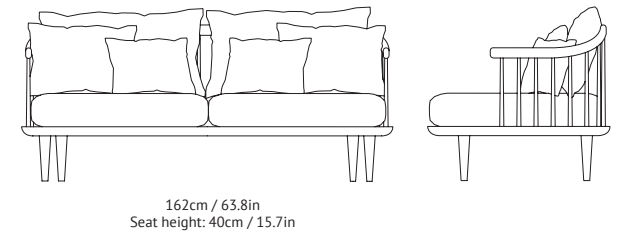

## FLY SOFA SC3

BY SPACE COPENHAGEN  
2013

**Product category** Sofa with side tables  
**Materials** Oak frame and base. CMHR foam and feather pillows. Fabric upholstery.  
**Dimensions (cm/in)** H: 70cm/27.6in, D: 80cm/31.5in, L: 240cm/94.5in, Seat height: 40cm/15.7in.  
**Stock items** White oiled oak/Chivasso Hot Madison (CH1249/094), Smoked oiled oak/Chivasso Hot Madison (CH1249/093), Smoked oiled oak/Harald 182.  
**6 wks. lead-time** All other fabrics, leathers and COM available with white oiled or smoked oiled oak base and frame.

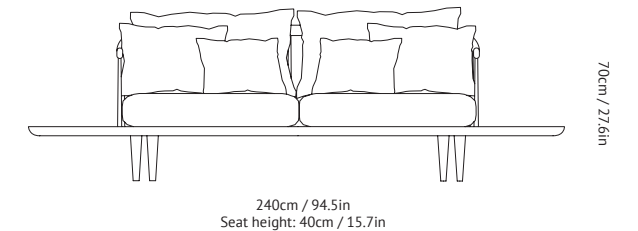



## FLY POUF SC9

BY SPACE COPENHAGEN  
2014

**Product category** Pouf  
**Materials** Oak base. CMHR foam and feather pillow. Fabric upholstery.  
**Dimensions (cm/in)** H: 40cm/15.7in, D: 80cm/31.5in, L: 80cm/31.5in. Seat height: 40cm/15.7in.  
**Stock items** White oiled oak/Chivasso Hot Madison (CH1249/094), Smoked oiled oak/Chivasso Hot Madison (CH1249/093), Smoked oiled oak/Harald 182.  
**6 wks. lead time** All other fabrics, leathers and COM available with white oiled or smoked oiled oak base and frame.

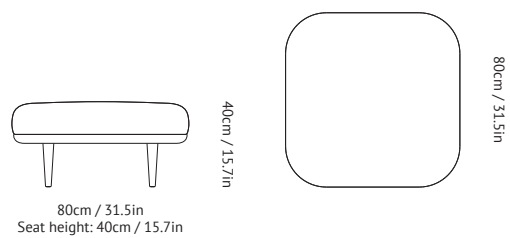

## FLY TABLE SC4

BY SPACE COPENHAGEN  
2013

**Product category** Lounge table  
**Materials** Oak base with marble table top  
**Dimensions (cm/in)** H: 26cm/10.2in, D: 80cm/31.5in, L: 80cm/31.5in  
**Colours** White oiled oak & honed Bianco Carrara marble  
 White oiled oak & honed Pietra di Fossena  
 Smoked oiled oak & honed Pietra di Fossena  
 Smoked oiled oak & honed Nero Marquina marble

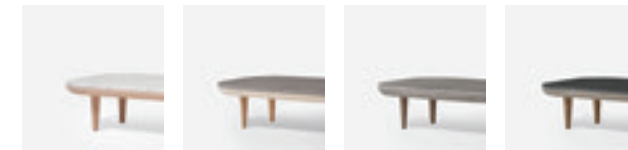
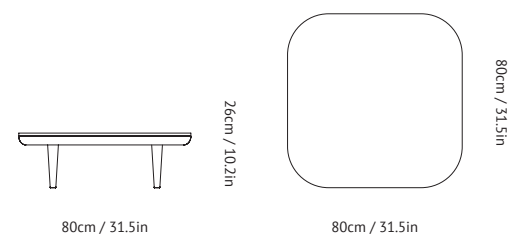

## FLY TABLE SC5

BY SPACE COPENHAGEN  
2013

**Product category** Lounge table  
**Materials** Oak base with marble table top  
**Dimensions (cm/in)** H: 26cm/10.2in, D: 60cm/23.6in, L: 120cm/47.2in  
**Stock items** White oiled oak & honed Bianco Carrara marble  
 White oiled oak & honed Pietra di Fossena  
 Smoked oiled oak & honed Pietra di Fossena  
 Smoked oiled oak & honed Nero Marquina marble

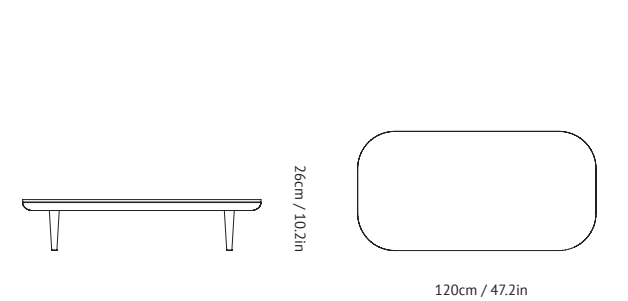

## FLY TABLE SC11

BY SPACE COPENHAGEN  
2017

**Product category** Lounge table  
**Materials** Oak base with marble table top  
**Dimensions (cm/in)** H: 32cm/12.6in, D: 120cm/47.2in, L: 120cm/47.2in  
**Stock items** White oiled oak & honed Bianco Carrara marble  
 White oiled oak & honed Pietra di Fossena  
 Smoked oiled oak & honed Pietra di Fossena  
 Smoked oiled oak & honed Nero Marquina marble

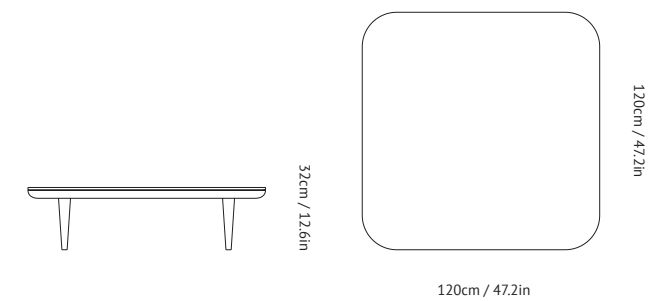

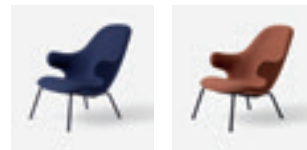

## CATCH LOUNGE JH13

BY JAIME HAYON  
2017

**Product category** Lounge chair  
**Materials** Molded PU foam, CMHR foam, steel base, fabric or leather upholstery.  
**Dimensions (cm/in)** H: 86cm/33.9in, W: 82cm/32.3in, D: 92cm/36.2in.  
 Armrest height: 58cm/22.8in.  
 Seat height: 36cm/14.2in.  
**8-10 wks. lead-time** Available in fabrics, leathers and as COM with warm black powder coated base.

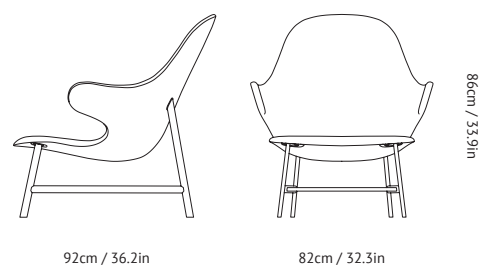

86cm / 33.9in

## CATCH LOUNGE JH14

BY JAIME HAYON  
2017

**Product category** Lounge chair  
**Materials** Molded PU foam, CMHR foam, steel base, fabric or leather upholstery.  
**Dimensions (cm/in)** H: 86cm/33.9in, W: 82cm/32.3in, D: 92cm/36.2in.  
 Armrest height: 58cm/22.8in.  
 Seat height: 36cm/14.2in.  
**8-10 wks. lead-time** Available in fabrics, leathers and as COM with warm black powder coated base.

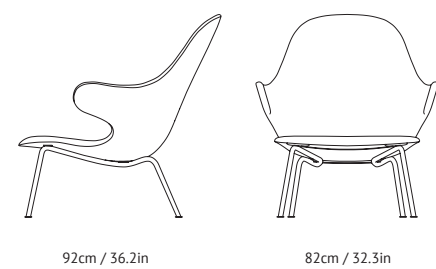

86cm / 33.9in

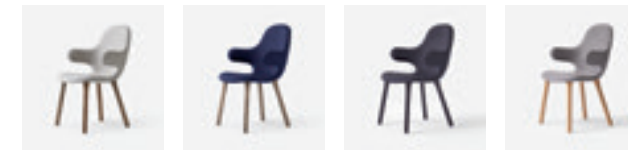

## CATCH CHAIR JH1

BY JAIME HAYON  
2014

**Product category** Chair with armrest  
**Materials** Molded PU foam, CMHR foam, oak legs, fabric or leather upholstery.  
**Dimensions (cm/in)** H: 90cm/35.4in, D: 58cm/22.8in, W: 58cm/22.8in,  
 Armrest height: 68cm/26.8in.  
 Seat height: 45cm/17.7in.  
**6-8 wks. lead-time** Available in fabrics, leathers and as COM with white oiled, smoked oiled, or black lacquered solid oak legs.

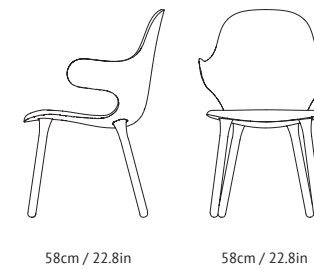

90cm / 35.4in

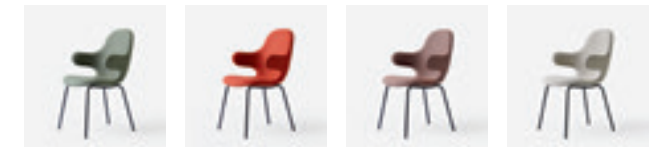

## CATCH CHAIR JH15

BY JAIME HAYON  
2017

**Product category** Chair with armrest  
**Materials** Molded PU foam, CMHR foam, tube base, fabric or leather upholstery.  
**Dimensions (cm/in)** H: 90cm/35.4in, D: 58cm/22.8in, W: 58cm/22.8in,  
 Armrest height: 68cm/26.8in.  
 Seat height: 45cm/17.7in.  
**6-8 wks. lead-time** Available in fabrics, leathers and as COM with black powder coated tube base.

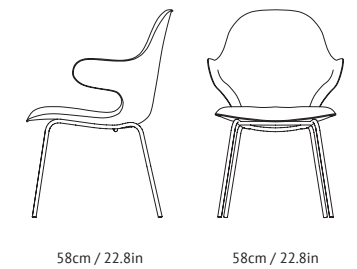

90cm / 35.4in



## CATCH CHAIR JH2

BY JAIME HAYON  
2014

**Product category** Chair with armrest  
**Materials** Molded PU foam, CMHR foam, aluminium swivel base, fabric or leather upholstery.  
**Dimensions (cm/in)** H: 90cm/35.4in, D: 58cm/22.8in, W: 58cm/22.8in, Armrest height: 68cm/26.8in, Seat height: 45cm/17.7in.  
**6-8 wks.lead-time** Available in fabrics, leathers and as COM with polished or black powder coated aluminium swivel base.

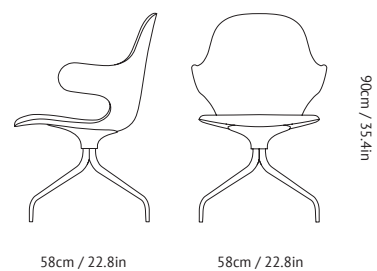

## IN BETWEEN SK1

BY SAMI KALLIO  
2013

**Product category** Chair with armrest  
**Materials** Solid oak and formpressed oak veneer  
**Dimensions (cm/in)** H: 77cm/30.3in, W: 58cm/22.8in, D: 54cm/21.2in, Armrest height: 70cm/27.6in, Seat height: 45cm/17.7in.  
**Colours** White oiled oak, smoked oiled oak, stained black ash (RAL 9005).

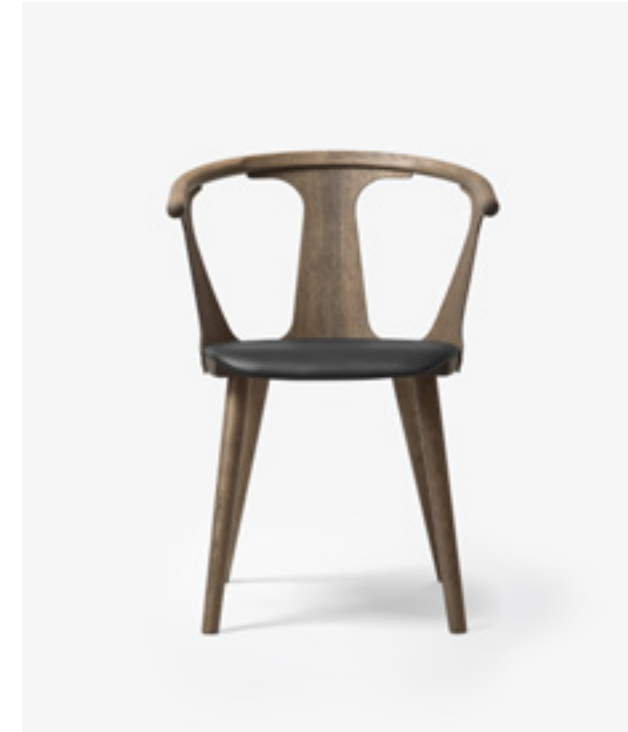
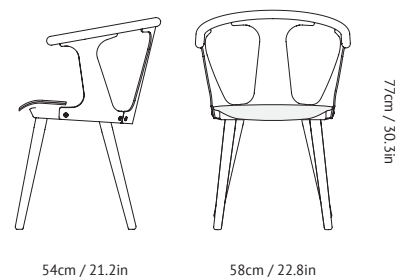

## IN BETWEEN SK2

BY SAMI KALLIO  
2013

**Product category** Chair with armrest  
**Materials** Solid oak and formpressed veneer  
**Dimensions (cm/in)** H: 77cm/30.3in, W: 58cm/22.8in, D: 54cm/21.2in, Armrest height: 70cm/27.6in, Seat height: 45cm/17.7in.  
**Stock items** White oiled oak with Fiord 251, White oiled oak with Cognac Silk leather, Smoked oiled oak with Fiord 171, Smoked oiled oak with Black Silk leather, Black stained ash with Fiord 191, Black stained ash with Black Silk leather.  
**6-8 wks. lead-time** Available in fabrics, leathers and as COM with white oiled, smoked oiled or black stained frame.

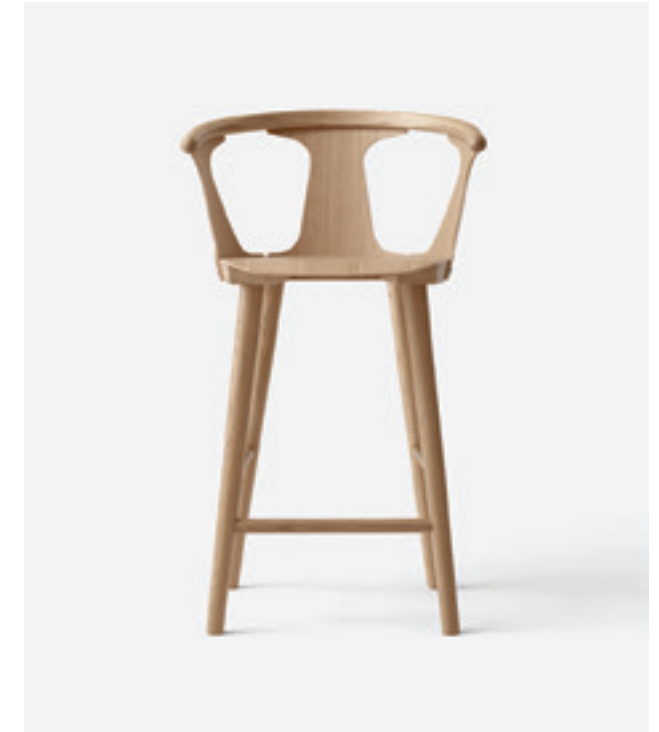
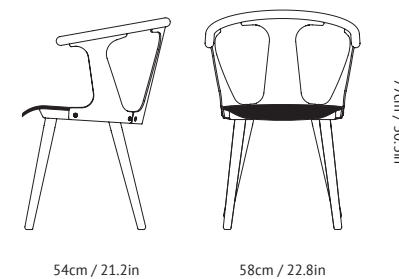

## IN BETWEEN SK7 & SK9

BY SAMI KALLIO  
2017

**Product category** Barstool  
**Materials** Solid oak and formpressed oak veneer  
**Dimensions (cm/in)** SK7: H: 92cm/36.2in, W: 58cm/22.8in, D: 54cm/21.2in, Armrest height: 88cm/34.6in, Seat height: 65cm/26.3in. SK9: H: 102cm/40.2in, W: 58cm/22.8in, D: 54cm/21.2in, Armrest height: 98cm/38.6in, Seat height: 75cm/30.2in.  
**Stock items** White oiled oak, smoked oiled oak, black lacquered oak.

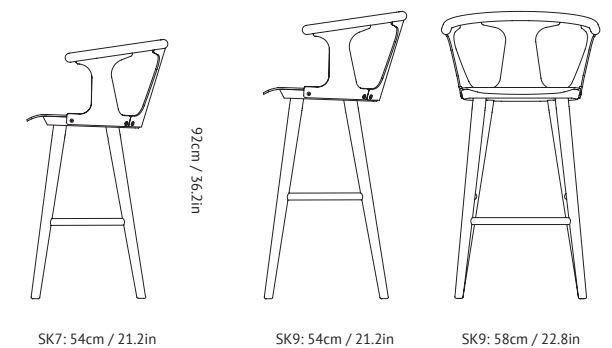

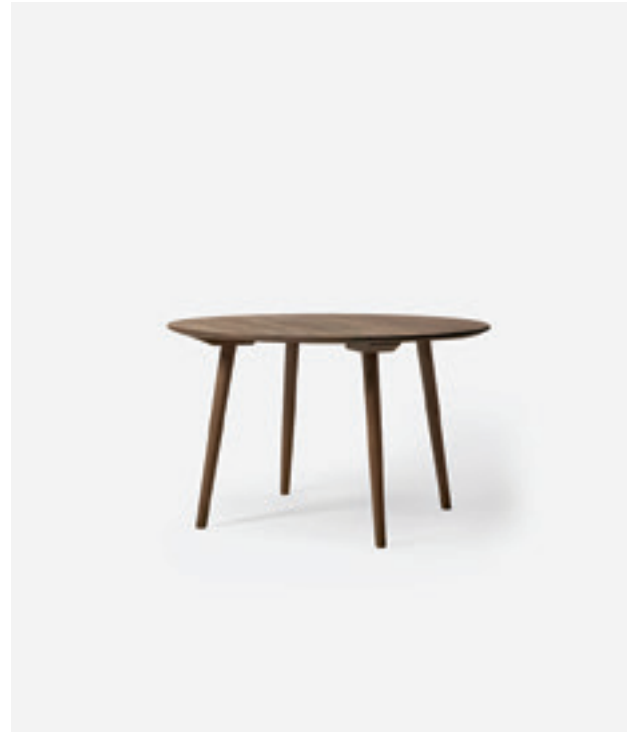

## IN BETWEEN SK8 & SK10

BY SAMI KALLIO  
2017

**Product category** Barstool  
**Materials** Solid oak and formpressed oak veneer  
**Dimensions (cm/in)** SK8: H: 92cm/36.2in, W: 58cm/22.8in, D: 54cm/21.2in. Armrest height: 88cm/34.6in. Seat height: 65cm/26.3in.  
 SK10: H: 102cm/40.2in, W: 58cm/22.8in, D: 54cm/21.2in. Armrest height: 98cm/38.6in. Seat height: 75cm/30.2in.  
**6-8 wks. lead-time** Other fabrics/leathers and COM available upon request.

## IN BETWEEN SK3 & SK4

BY SAMI KALLIO  
2014

**Product category** Dining table  
**Materials** Solid oak  
**Dimensions (cm/in)** SK3: Ø: 90cm/35.4in, H: 73cm/28.7in.  
 SK4: Ø: 120cm/47.2in, H: 73cm/28.7in.  
**Colours** White oiled oak, Smoked oiled oak, Black stained oak (RAL 9005).

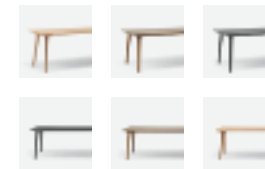
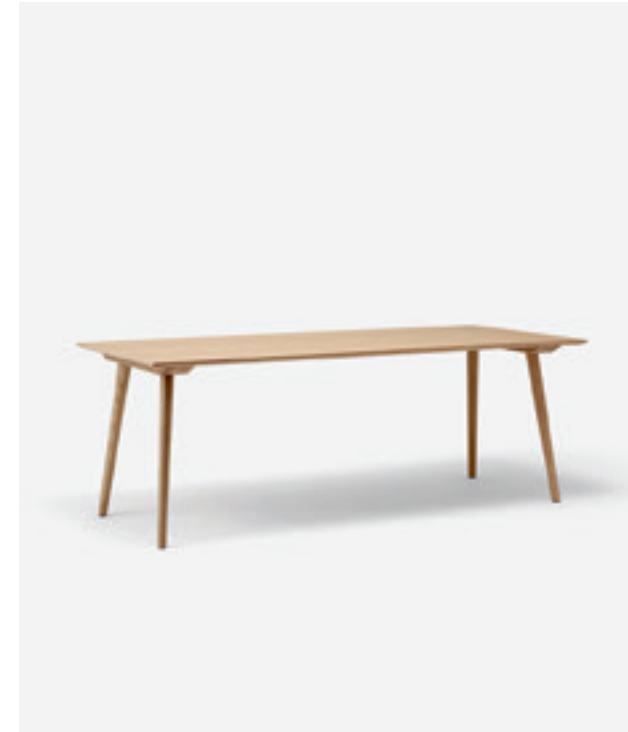
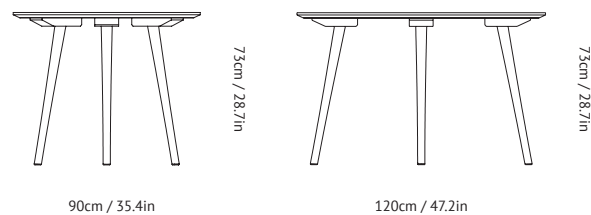
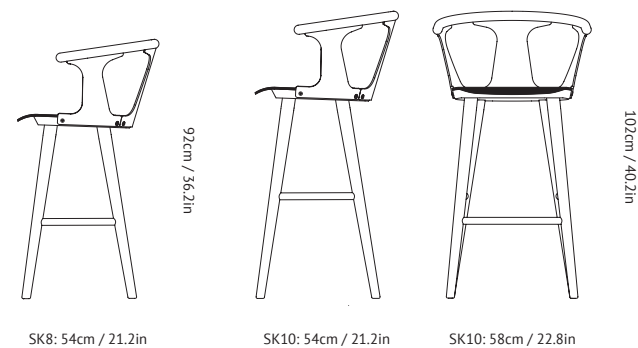

## IN BETWEEN SK5 & SK6

BY SAMI KALLIO  
2015

**Product category** Dining table  
**Materials** Lacquered solid oak and oak veneer, Stained solid oak and oak veneer.  
**Dimensions (cm/in)** SK5: D: 200cm/78.7in, W: 90cm/35.4in, H: 73cm/28.7in. SK6: D: 250cm/98.4in, W: 100cm/39.4in, H: 73cm/28.7in.  
**Colours** Clear lacquered oak, Smoked stained oak, Black stained oak.  
**6-8 wks. lead-time** Available in custom sizes with veneer, laminate, nano laminate and linoleum table top upon request.

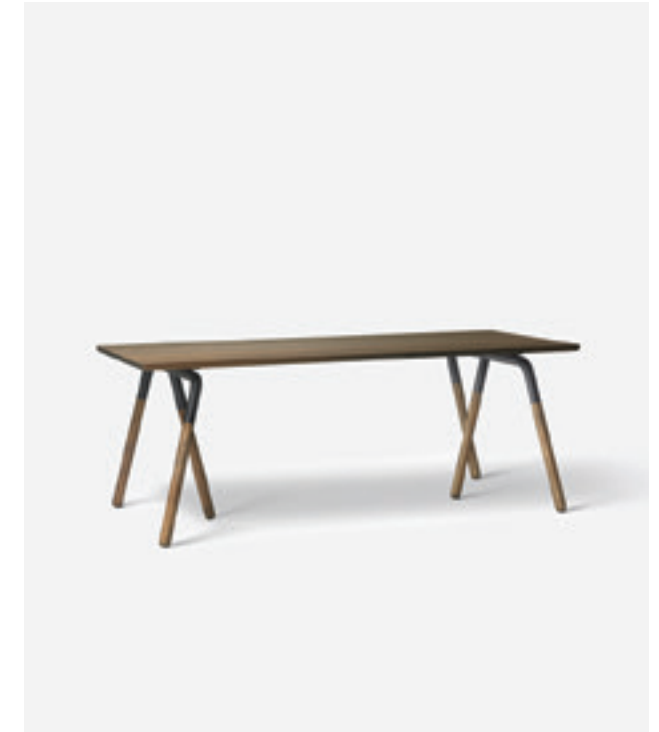
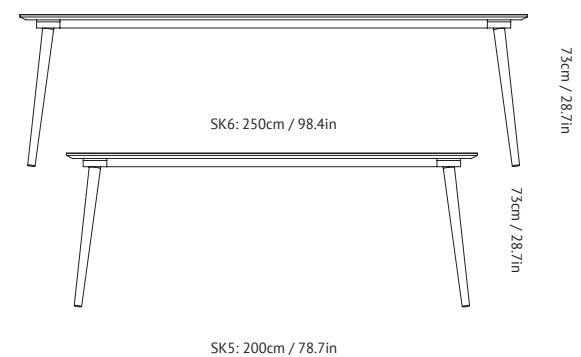

## NA TABLE NA2

BY NORM.ARCHITECTS  
2011

**Product category** Dining table  
**Materials** Powdercoated steel structure and sand blasted solid oak legs with table top in either ash veneer, laminate or solid oak.  
**Dimensions (cm/in)** H: 75cm/29.5in, D: 90cm/35.4in, L: 200cm/78.7in.  
**Colours** Black powdercoated steel with black stained oak legs and black stained ash veneer table top. White powdercoated steel with natural oak legs and white laminate table top. Black powder coated steel with smoked oiled oak legs and table top.

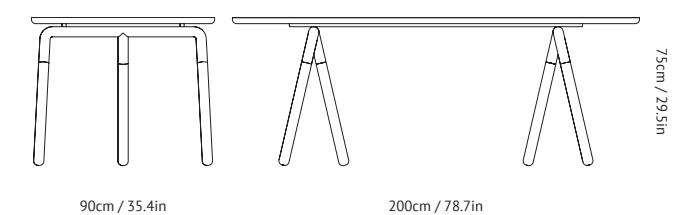



## HOOF TABLE SW1

BY SAMUEL WILKINSON  
2012

**Product category** Coffee table  
**Materials** Solid oak with a brushed surface  
**Dimensions (cm/in)** Ø: 50cm/19.7in, H: 50cm/19.7in  
**Colours** Solid white oiled oak  
 Solid smoked oiled oak  
 Solid black stained oak (RAL 9005)

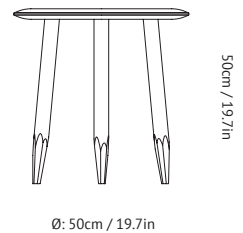

Ø: 50cm / 19.7in

## HOOF TABLE SW2

BY SAMUEL WILKINSON  
2012

**Product category** Coffee table  
**Materials** Solid oak with a brushed surface  
**Dimensions (cm/in)** Ø: 90cm/35.4in, H: 40cm/15.7in.  
**Colours** Solid white oiled oak  
 Solid smoked oiled oak  
 Solid black stained oak (RAL 9005)

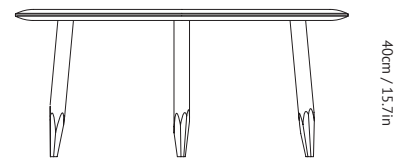

Ø: 90cm / 35.4in



## NA STOOL NA3

BY NORM.ARCHITECTS  
2011

**Product category** Stool  
**Materials** Powdercoated steel and sandblasted solid oak  
**Dimensions (cm/in)** H: 46cm/18.1in, D: 45cm/17.7in, W: 50cm/19.7in.  
**Colours** Natural oak with white powder coated steel (RAL 9016), Black stained oak with black powder coated steel (RAL 9005).

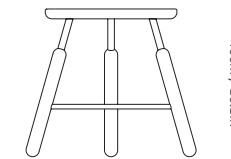

45cm / 17.7in



## NA BARSTOOL NA4

BY NORM.ARCHITECTS  
2011

**Product category** Barstool  
**Materials** Powdercoated steel and sandblasted solid oak  
**Dimensions (cm/in)** H: 73cm/28.7in, D: 45cm/17.7in, W: 50cm/19.7in.  
**Colours** Natural oak with white powder coated steel (RAL 9016), Black stained oak with black powder coated steel (RAL 9005).

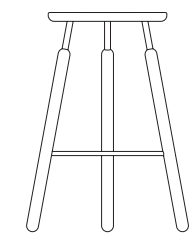

Ø: 45cm / 17.7in



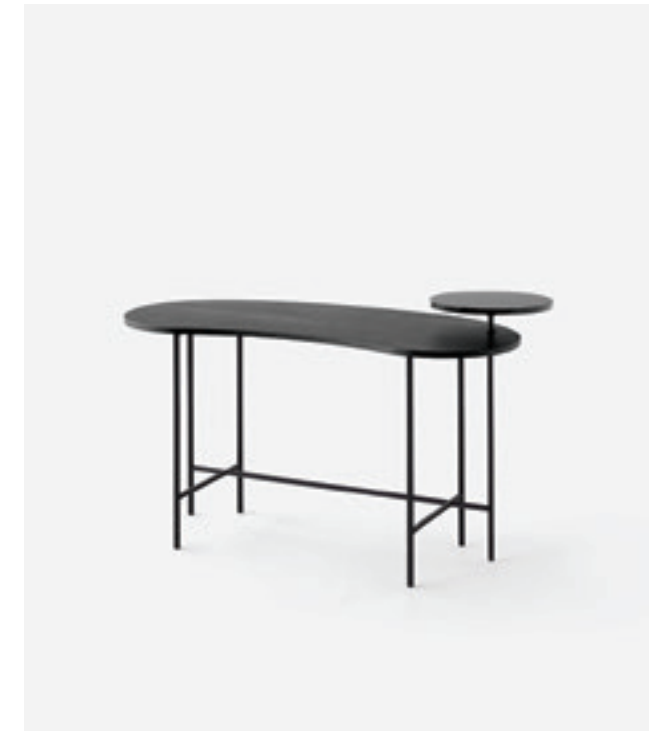

## PALETTE JH6

BY JAIME HAYON  
2015

**Product category** Lounge table  
**Materials** Stainless steel, white Bianco Carrara marble, pale pink stained ash.  
**Dimensions (cm/in)** D: 82.5cm/32.5in, W: 70.8cm/27.9in, H: 46.7cm/18.4in.

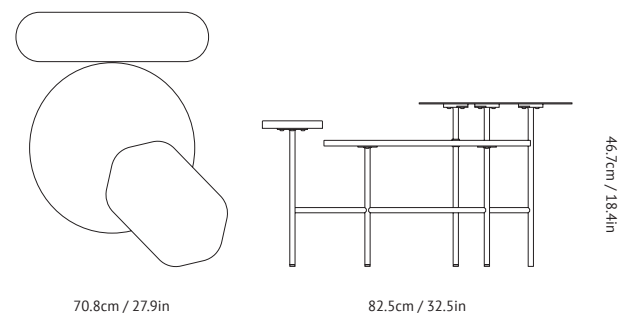

70.8cm / 27.9in

82.5cm / 32.5in

46.7cm / 18.4in

## PALETTE JH7

BY JAIME HAYON  
2015

**Product category** Lounge table  
**Materials** Brass, black Nero Marquina marble, black stained ash.  
**Dimensions (cm/in)** D: 115.2cm/45.4in, W: 67.8cm/26.7in, H: 47cm/18.5in.

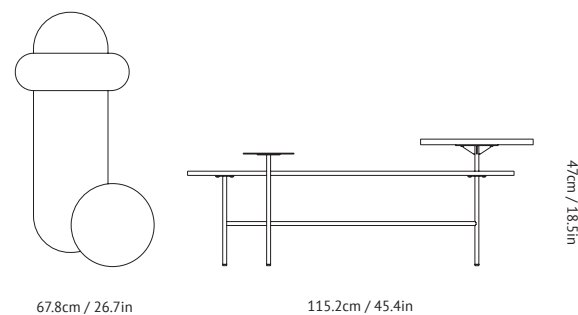

67.8cm / 26.7in

115.2cm / 45.4in

47cm / 18.5in

## PALETTE JH8

BY JAIME HAYON  
2015

**Product category** Lounge table  
**Materials** Brass, red Rosso Levanto marble, blue stained ash.  
**Dimensions (cm/in)** D: 66.3cm/26in, W: 54.9cm/21.6in, H: 57cm/22.4in.

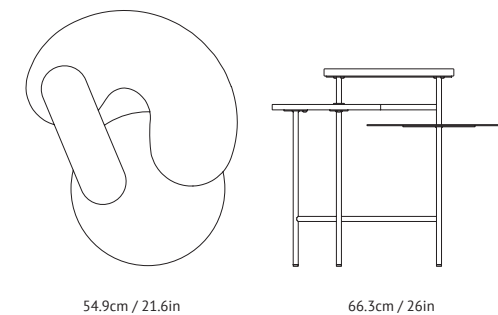

54.9cm / 21.6in

66.3cm / 26in

57cm / 22.4in

## PALETTE DESK JH9

BY JAIME HAYON  
2015

**Product category** Desk  
**Materials** Polished black Nero Marquina marble, black stained ash veneer. Honed white Bianco Carrara marble, red stained ash veneer. Satin polished brass, grey-green stained ash veneer.  
**Dimensions (cm/in)** H: 73/83cm/28.7/32.7in, D: 62cm/24.4in, L: 146cm/57.5in.

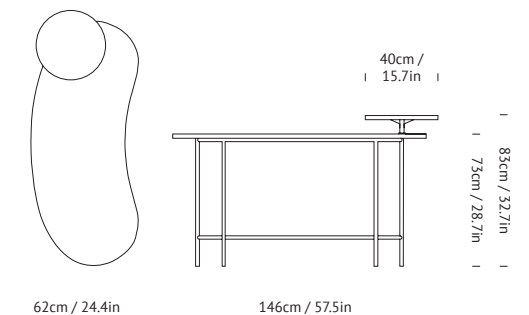

62cm / 24.4in

146cm / 57.5in

40cm / 15.7in

83cm / 32.7in  
73cm / 28.7in

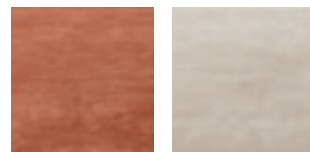

## THE MOOR AP5 & AP7

BY ALL THE WAY TO PARIS  
2016

**Product category** Rug  
**Materials** Handloom-woven rug with a dense, soft and highly exclusive velvet-like expression made from 85% pure New Zealand wool, 15% viscose.  
**Dimensions (cm/in)** AP5: W: 170cm/66.9in, L: 240cm/94.5in.  
 AP7: W: 200cm/78.7in, L: 300cm/118.1in.  
**Colours** Grey moss, Beige dew

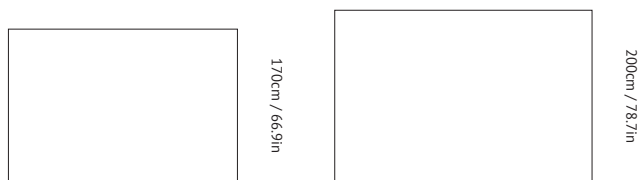

AP5: 240cm / 94.5in

AP7: 300cm / 118.1in

## THE MOOR AP6

BY ALL THE WAY TO PARIS  
2016

**Product category** Rug  
**Materials** Handloom-woven rug with a dense, soft and highly exclusive velvet-like expression made from 85% pure New Zealand wool, 15% viscose.  
**Dimensions (cm/in)** W: 240cm/94.5in, L: 240cm/94.5in.  
**Colours** Red heather, Beige dew

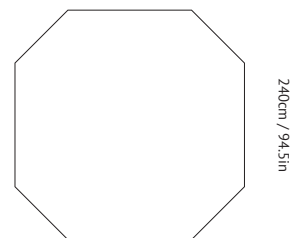

240cm / 94.5in



## THE MOOR AP8

BY ALL THE WAY TO PARIS  
2016

**Product category** Rug  
**Materials** Handloom-woven rug with a dense, soft and highly exclusive velvet-like expression made from 85% pure New Zealand wool, 15% viscose.  
**Dimensions (cm/in)** W: 300cm/118.1in, L: 300cm/118.1in.  
**Colours** Blue midnight, Grey moss

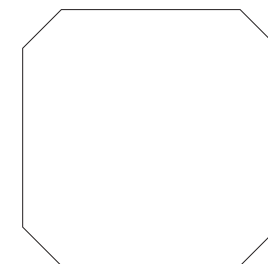

300cm / 118.1in

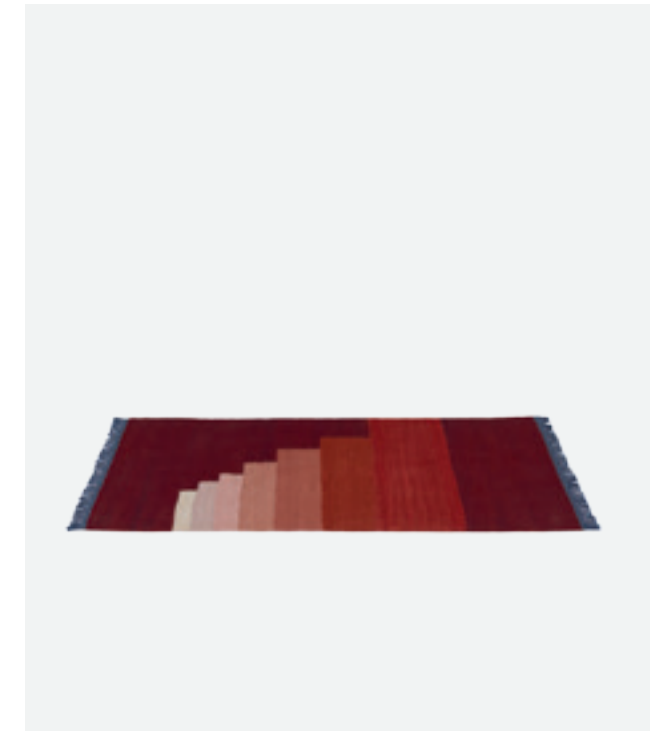

## ANOTHER RUG AP1 – AP4

BY ALL THE WAY TO PARIS  
2014

**Product category** Rug  
**Materials** Handwoven kelim rug made from carefully selected natural materials. 80% pure New Zealand wool, 20% cotton.  
**Dimensions (cm/in)** AP1: W: 90cm/35.4in, L: 140cm/55.1in.  
 AP2: W: 90cm/35.4in, L: 240cm/94.5in.  
 AP3: W: 170cm/66.9in, L: 240cm/94.5in.  
 AP4: W: 200cm/78.7in, L: 300cm/118.1in.  
**Colours** Red Volcano, Blue Thunder, Green Jade, Yellow Amber.

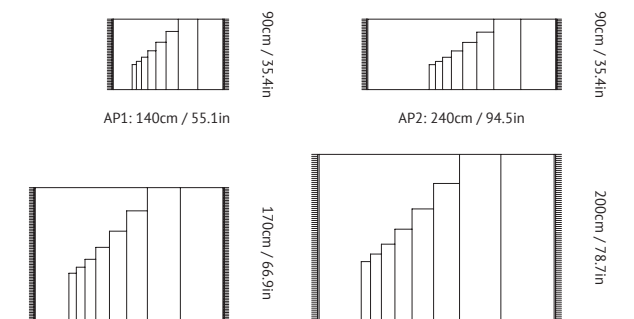

AP1: 140cm / 55.1in

AP2: 240cm / 94.5in

AP3: 240cm / 94.5in

AP4: 300cm / 118.1in

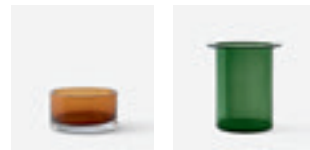

## 721 GRAMS IG1

BY ISABELL GATZEN  
2016

**Product category** Candle holder  
**Materials** Brass  
**Dimensions (cm/in)** H: 4.8cm/1.9in, D: 2.4cm/0.9in, W: 14cm/5.5in

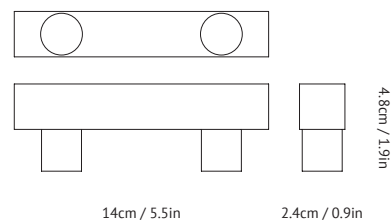

## TRICOLORE SH1

BY SEBASTIAN HERKNER  
2017

**Product category** Vases  
**Materials** Mouth-blown coloured bohemian glass  
**Dimensions (cm/in)** Inner vase: Ø: 18cm/7.1in, H: 20cm/7.9in  
Bottom vase: Ø: 17cm/6.7in, H: 9cm/3.5in  
**Colours** Malachite & Cornaline

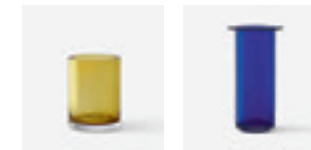
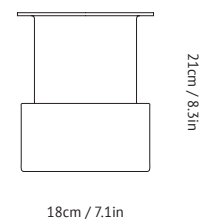

## TRICOLORE SH2

BY SEBASTIAN HERKNER  
2017

**Product category** Vases  
**Materials** Mouth-blown coloured bohemian glass  
**Dimensions (cm/in)** Inner vase: Ø: 14cm/5.5in, H: 25cm/9.8in.  
Bottom vase: Ø: 13cm/5.1in x H: 17cm/6.7in.  
**Colours** Amber & Lapis

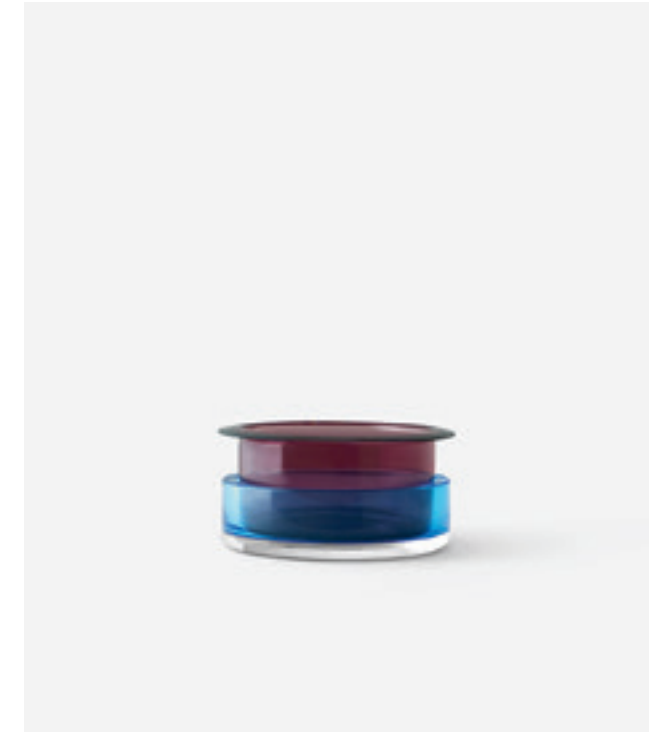
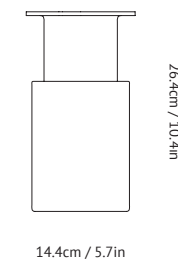

## TRICOLORE SH3

BY SEBASTIAN HERKNER  
2017

**Product category** Vases  
**Materials** Mouth-blown coloured bohemian glass  
**Dimensions (cm/in)** Inner vase: Ø: 22cm/8.7in, H: 9cm/3.5in.  
Bottom vase: Ø: 21cm/8.3in, H: 6cm/2.3in.  
**Colours** Topaz & Rubis

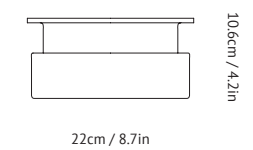

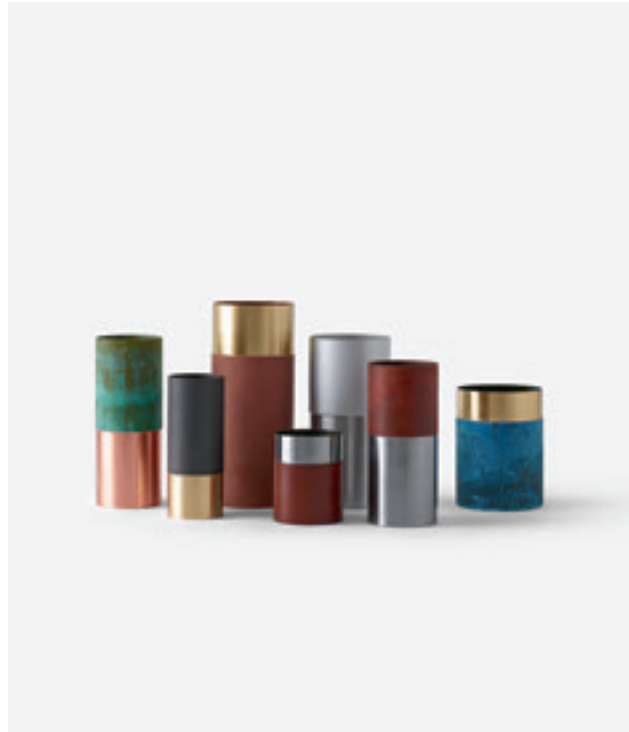

## TRUE COLOURS LP1 – LP7

BY LEX POTT  
2013

**Product category** Vases  
**Materials** Brass, Aluminium, Copper, Steel  
**Dimensions (cm/in)** LP1: Ø: 10cm/3.9in, H: 20cm/7.9in  
 LP2: Ø: 10cm/3.9in, H: 24cm/9.4in  
 LP3: Ø: 8cm/3.1in, H: 20cm/7.9in  
 LP4: Ø: 8cm/3.1in, H: 10cm/3.9in  
 LP5: Ø: 10cm/3.9in, H: 14cm/5.5in  
 LP6: Ø: 6.5cm/2.6in, H: 16cm/6.3in  
 LP7: Ø: 8cm/3.1in, H: 18cm/7.1in  
**Colours** White aluminium, terracotta brass, green copper, brown aluminium, blue brass, black brass, brown steel.

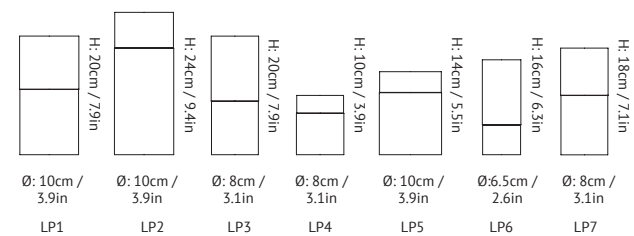

## FORNELL ABF1

BY ANDREAS BOZARTH FORNELL  
2017

**Product category** Pendant  
**Materials** Mirror polished & matt lacquered stainless steel, PC diffuser, 6m cable & stainless steel wires  
**Dimensions (cm/in)** Lamp shade: H: 6cm/2.4in, L: 120cm/47.2in, W: 7.5cm/2.9in. Canopy: H: 4cm/1.6in, L: 49cm/19.3in, W: 5cm/1.9in  
**Colours** Mirror polished stainless steel & matt white  
 Mirror polished stainless steel & matt black  
**Light source** Light source: 24 Watt dimmable LED.  
 The luminaire is compatible with bulbs of the energy classes: A++ - A. The built-in LEDs cannot be changed in this luminaire.

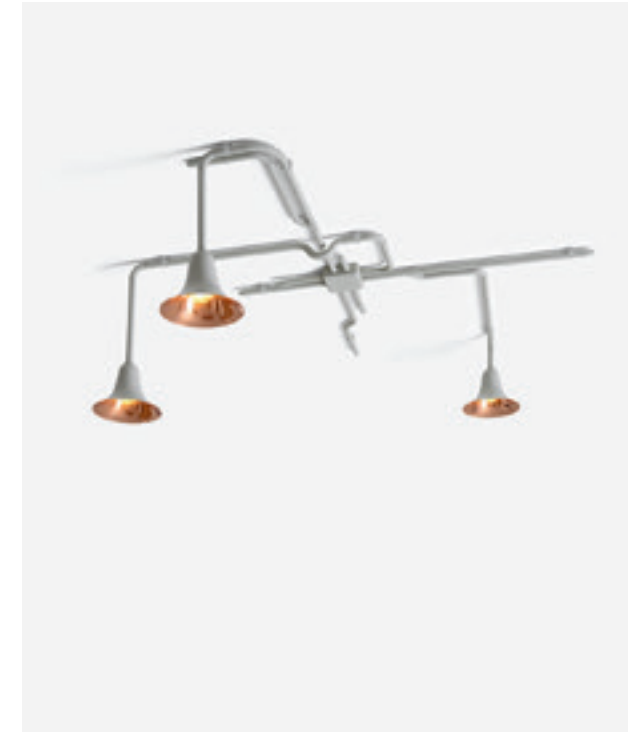
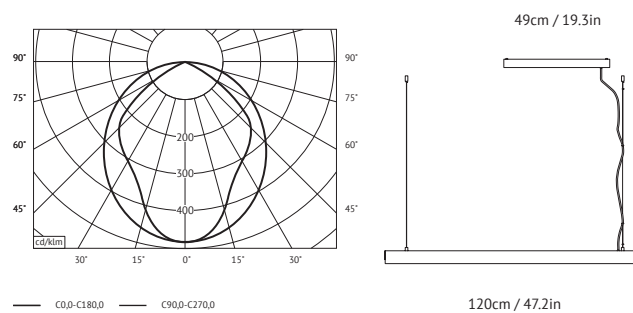

## LIGHT FOREST OD1

BY ONTWERPDUO  
2010

**Product category** Ceiling light  
**Materials** Lacquered copper, aluminium and ABS.  
**Dimensions (cm/in)** Conf. 1: W: 100cm/39.4in, D: 100cm/39.4in.  
 Conf. 2: W: 125cm/49.2in, D: 120cm/47.2in.  
 Conf. 3: W: 145cm/57.1in, D: 75cm/29.5in.  
 Conf. 4: W: 100cm/39.4in, D: 75cm/29.5in.  
**Colours** Slightly textured matt forest green.  
**Light source** 3 x E27 Max 40 Watt. The luminaire is compatible with bulbs of the energy classes: A++ - E. Bulb is not included.

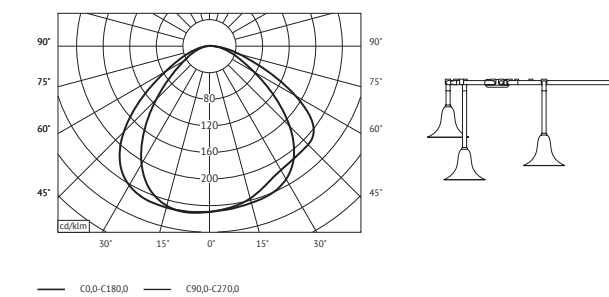

## LIGHT FOREST OD2

BY ONTWERPDUO  
2010

**Product category** Wall mounting set  
**Materials** Lacquered copper, aluminium, ABS, 3-meter clear pvc cord with CE plug.  
**Dimensions (cm/in)** Conf. 1: H: 120cm/47.2in, W: 70cm/27.6in.  
 Conf. 2: H: 95cm/37.4in, W: 150cm/59.1in.  
**Colours** Slightly textured matt forest green.  
**Light source** 3 x E27 Max 40 Watt. The luminaire is compatible with bulbs of the energy classes: A++ - E. Bulb is not included.

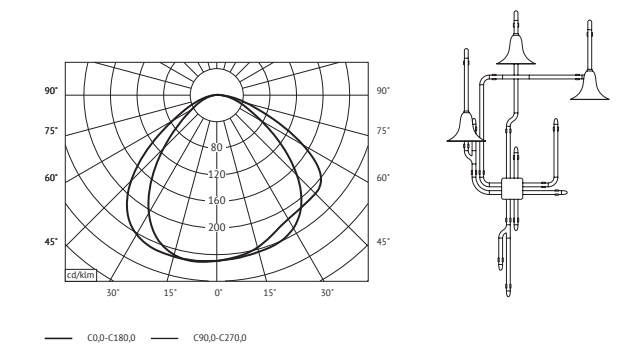

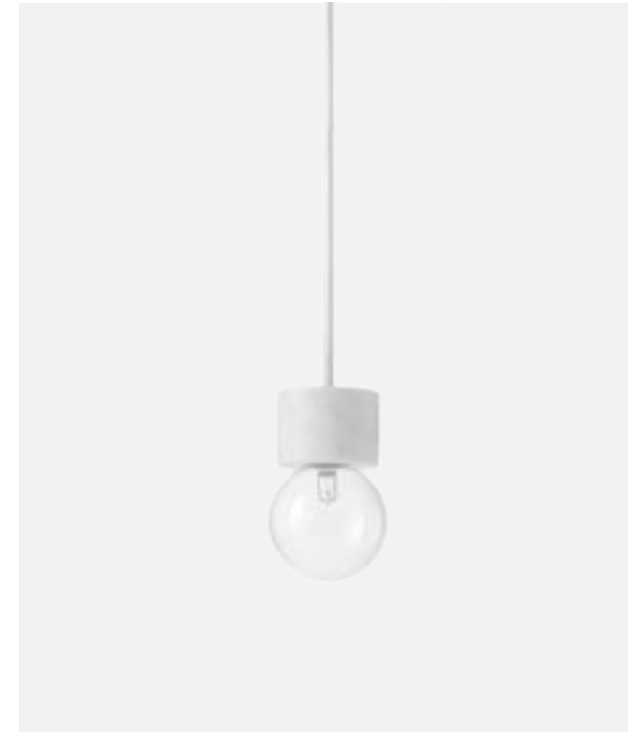

## MARBLE LIGHT SV1

BY STUDIO VIT  
2014

- Product category** Pendant
- Materials** White Bianco Carrara marble and clear mouth blown borosilicate glass with 4-meter white fabric cord.
- Dimensions (cm/in)** Marble: Ø: 11,5cm/4.5in, H: 7cm/2.7in.  
Glass: Ø: 8cm/3.1in.
- Light source** G9 Max 25 Watt. This luminaire is compatible with bulbs of the energy classes: B - E. Bulb is not included.

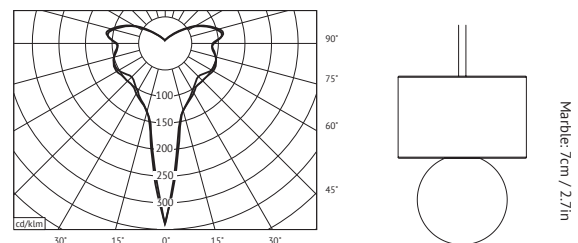

Marble: Ø: 11,5cm / 4.5in, Glass: Ø: 8cm / 3.1in

## MARBLE LIGHT SV2

BY STUDIO VIT  
2014

- Product category** Pendant
- Materials** White Bianco Carrara marble and clear mouth blown borosilicate glass with 4-meter white fabric cord.
- Dimensions (cm/in)** Marble: Ø: 8cm/3.1in, H: 10cm/3.9in.  
Glass: Ø: 13cm/5.1in.
- Light source** G9 Max 25 Watt. This luminaire is compatible with bulbs of the energy classes: B - E. Bulb is not included.

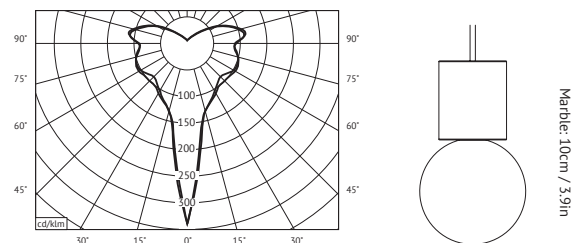

Marble: Ø: 8cm / 3.1in, Glass: Ø: 13cm / 5.1in

## MARBLE LIGHT SV3

BY STUDIO VIT  
2014

- Product category** Pendant
- Materials** White Bianco Carrara marble and clear mouth blown borosilicate glass with 4-meter white fabric cord.
- Dimensions (cm/in)** Marble: Ø: 7cm/2.7in, H: 5cm/1.9in.  
Glass: Ø: 8cm/3.1in.
- Light source** G9 Max 25 Watt. This luminaire is compatible with bulbs of the energy classes: B - E. Bulb is not included.

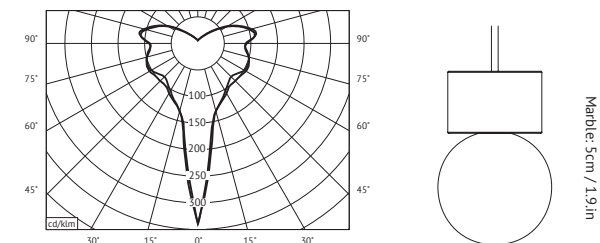

Marble: Ø: 7cm / 2.7in, Glass: Ø: 8cm / 3.1in

## MARBLE LIGHT SV4

BY STUDIO VIT  
2014

- Product category** Pendant
- Materials** White Bianco Carrara marble and clear mouth blown borosilicate glass with 4-meter white fabric cord.
- Dimensions (cm/in)** Marble: Ø: 9cm/3.5in, H: 6cm/2.3in.  
Glass: Ø: 11cm/4.3in.
- Light source** G9 Max 25 Watt. This luminaire is compatible with bulbs of the energy classes: B - E. Bulb is not included.

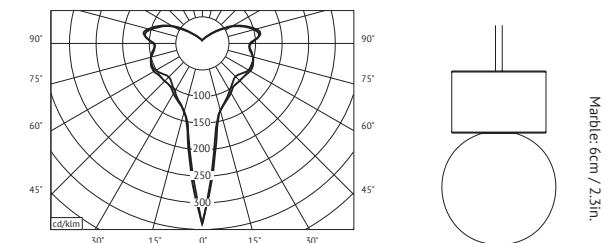

Marble: Ø: 9cm / 3.5in, Glass: Ø: 11cm / 4.3in



## MARBLE LIGHT SV5

BY STUDIO VIT  
2014

**Product category** Pendant  
**Materials** White Bianco Carrara marble and clear mouth blown borosilicate glass with 4-meter white fabric cord.  
**Dimensions (cm/in)** Marble: Ø: 5cm/1.9in, H: 16cm/6.3in.  
 Glass: Ø: 16cm/6.3in.  
**Light source** G9 Max 25 Watt. This luminaire is compatible with bulbs of the energy classes: B - E. Bulb is not included.

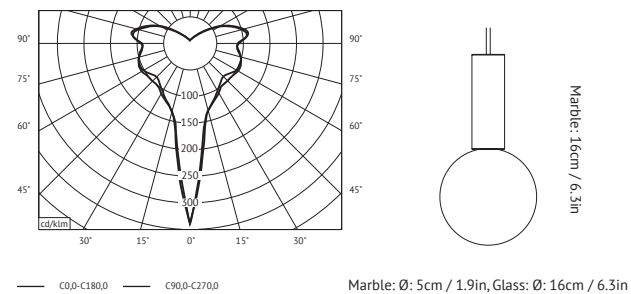

## MARBLE LIGHT SV6

BY STUDIO VIT  
2014

**Product category** Table lamp  
**Materials** White Bianco Carrara marble and clear mouth blown borosilicate glass with 2-meter white fabric cord with dimmer.  
**Dimensions (cm/in)** Marble: Ø: 7cm/2.7in, H: 5cm/1.9in.  
 Glass: Ø: 16cm/6.3in.  
**Light source** G9 Max 25 Watt. This luminaire is compatible with bulbs of the energy classes: B - E. Bulb is not included.

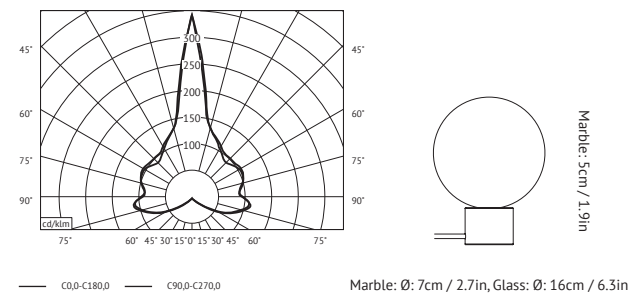

Marble: Ø: 7cm / 2.7in, Glass: Ø: 16cm / 6.3in



## MARBLE LIGHT SV7

BY STUDIO VIT  
2014

**Product category** Pendant (SV2) with marble floor weight and 10-meter cable.  
**Materials** White bianco carrara marble with 10-meter white fabric cord fitted with G9 lamp holder. The floor weight is delivered with a white metal hook for ceiling installation and a self-assembly CE plug.  
**Dimensions (cm/in)** Marble: Ø: 20cm/7.8in, H: 8cm/3.1in.  
**Light source** G9 Max 25 Watt. This luminaire is compatible with bulbs of the energy classes: B - E. Bulb is not included.

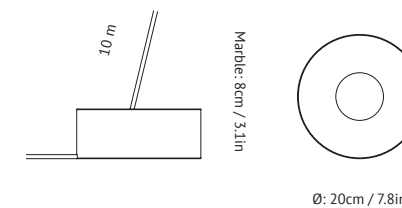

Ø: 20cm / 7.8in

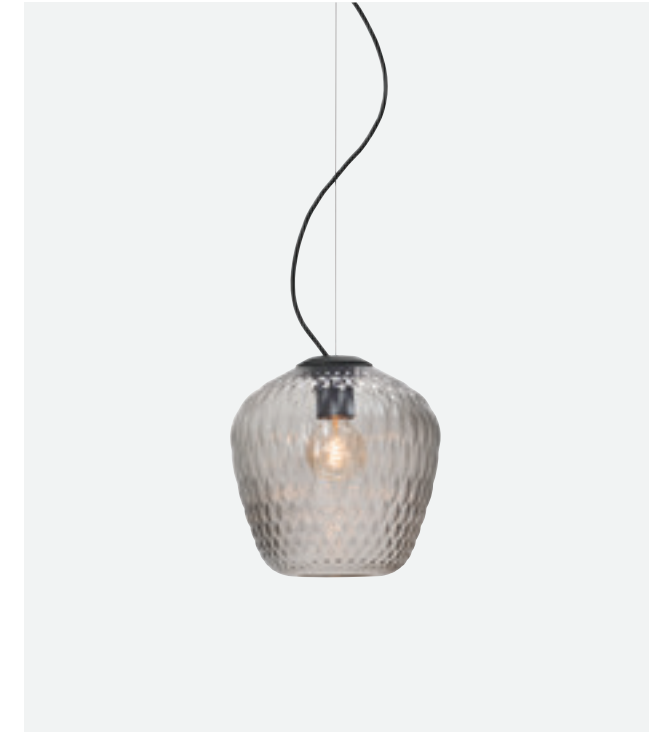

## BLOWN SW3

BY SAMUEL WILKINSON  
2014

**Product category** Pendant  
**Materials** Mouth-blown glass, powdercoated metal suspension, coated wire, 4-meter fabric cord.  
**Dimensions (cm/in)** Ø: 28cm/11in, H: 28cm/11in.  
**Colours** Silver lustre glass with black textile cord, Blasted white glass with white textile cord.  
**Light source** E27 Max 100 Watt. The luminaire is compatible with bulbs of the energy classes: A++ - E. Bulb is not included.

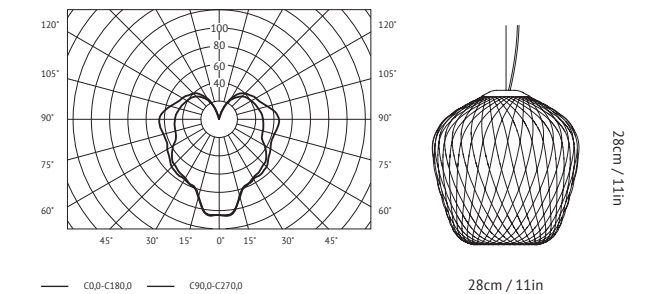

28cm / 11in

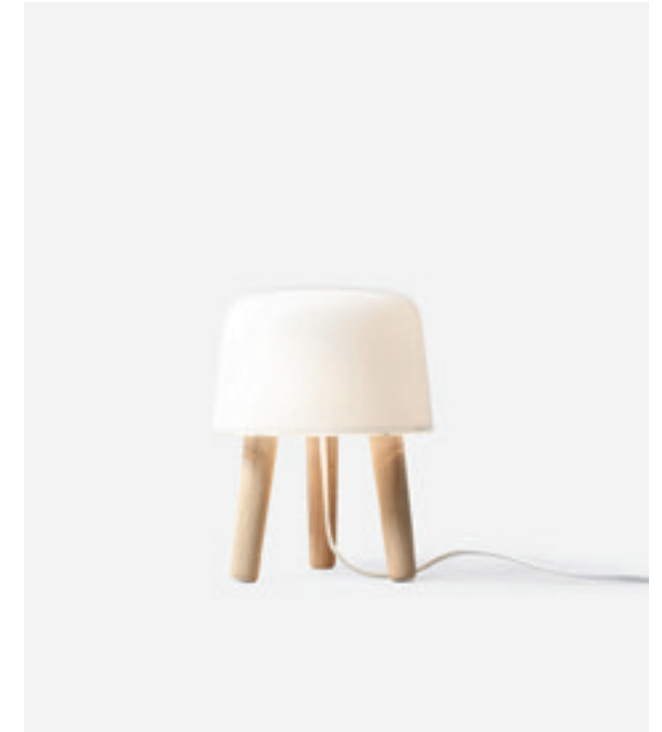
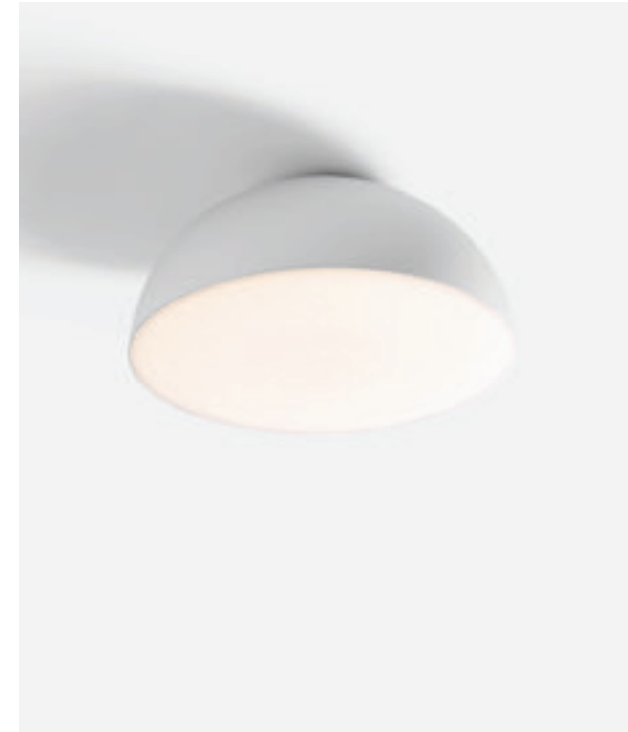

## PASSEPARTOUT JH10

BY JAIME HAYON  
2016

**Product category** Ceiling & wall lamp  
**Materials** Aluminium, Polycarbonate, ABS  
**Dimensions (cm/in)** Ø: 15.5cm/6.1in, H: 17cm/6.7in.  
**Colours** Matt white  
**Light source** 11,5 Watt dimmable LED. The luminaire is compatible with bulbs of the energy classes: A++ - A. The built-in LEDs cannot be changed in this luminaire.

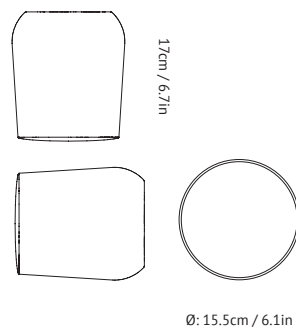

## PASSEPARTOUT JH11

BY JAIME HAYON  
2016

**Product category** Ceiling & wall lamp  
**Materials** Aluminium, Polycarbonate, ABS  
**Dimensions (cm/in)** Ø: 20cm/7.9in, H: 15.5cm/6.1in.  
**Colours** Matt white  
**Light source** 11,5 Watt dimmable LED. The luminaire is compatible with bulbs of the energy classes: A++ - A. The built-in LEDs cannot be changed in this luminaire.

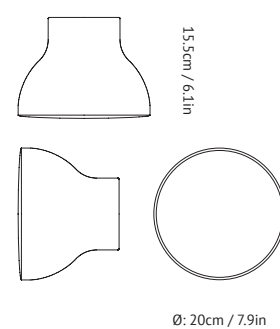

Ø: 20cm / 7.9in

## PASSEPARTOUT JH12

BY JAIME HAYON  
2016

**Product category** Ceiling & wall lamp  
**Materials** Aluminium, Polycarbonate, ABS  
**Dimensions (cm/in)** Ø: 28cm/11in, H: 12.5cm/4.9in.  
**Colours** Matt white  
**Light source** 11,5 Watt dimmable LED. The luminaire is compatible with bulbs of the energy classes: A++ - A. The built-in LEDs cannot be changed in this luminaire.

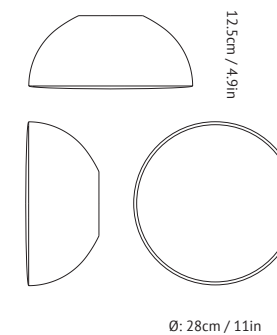

Ø: 28cm / 11in

## MILK NA1

BY NORM.ARCHITECTS  
2010

**Product category** Table lamp  
**Materials** Mouth blown opal glass, solid ash legs, 2-meter fabric cord with dimmer.  
**Dimensions (cm/in)** Ø: 20cm/7.9in, H: 25cm/9.8in.  
**Colours** Untreated ash legs with white fabric cord  
 Untreated ash legs with black fabric cord  
 Black stained ash legs with black fabric cord  
 Smoked oiled ash legs with black fabric cord  
**Light source** G9 Max 40 Watt. The luminaire is compatible with bulbs of the energy classes: B - E. Bulb is not included.

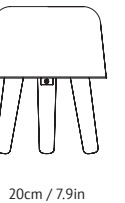
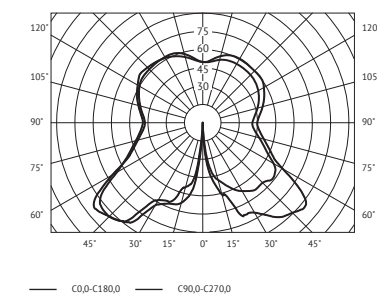

25cm / 9.8in

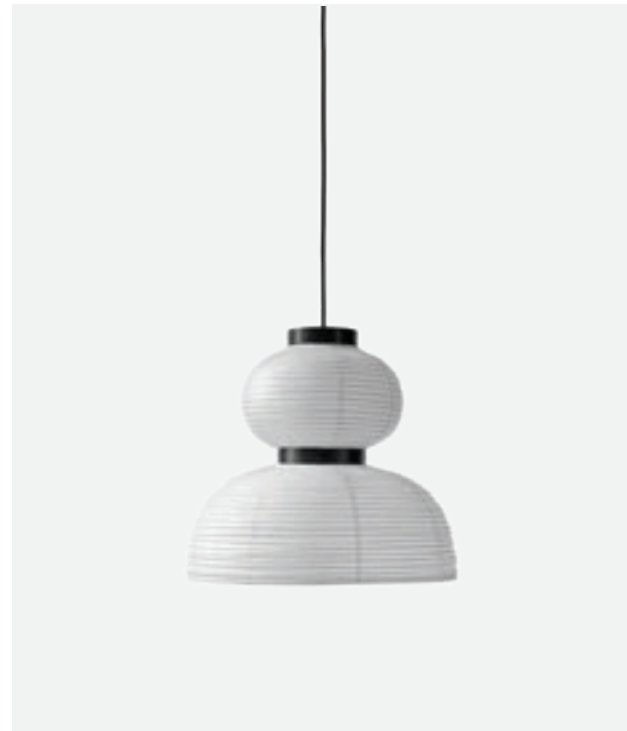
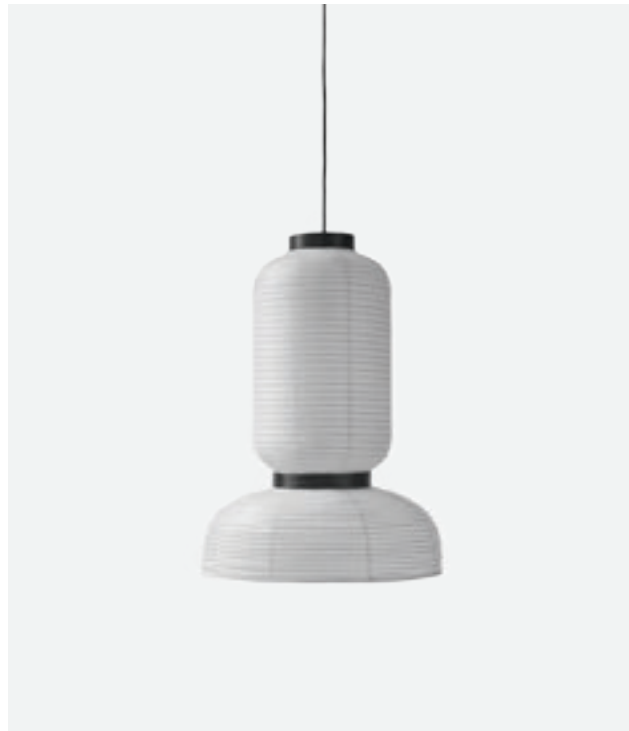

## FORMAKAMI JH3

BY JAIME HAYON  
2015

**Product category** Pendant  
**Materials** Ivory white paper, black stained oak, 4-meter black fabric cord.  
**Dimensions (cm/in)** Ø: 46cm/18.1in, H: 68cm/26.7in.  
**Colours** Ivory white paper with black stained oak.  
**Light source** E27 2 x Max 60 Watt.  
 The luminaire is compatible with bulbs of the energy classes: A++ - E. Bulb is not included.

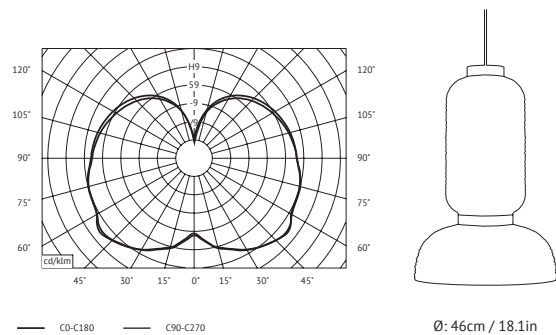

## FORMAKAMI JH4

BY JAIME HAYON  
2015

**Product category** Pendant  
**Materials** Ivory white paper, black stained oak, 4-meter black fabric cord.  
**Dimensions (cm/in)** Ø: 50cm/19.7in, H: 50cm/19.7in.  
**Colours** Ivory white paper with black stained oak.  
**Light source** E27 2 x Max 60 Watt.  
 The luminaire is compatible with bulbs of the energy classes: A++ - E. Bulb is not included.

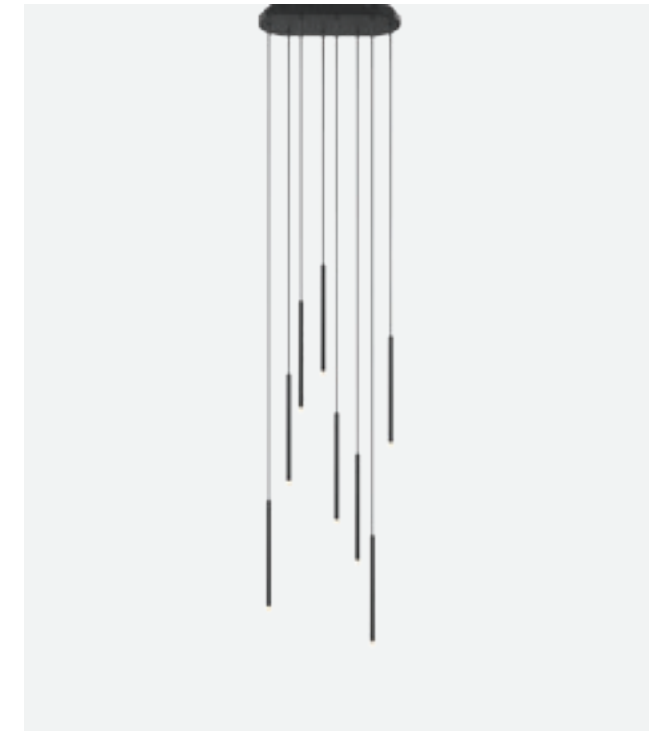
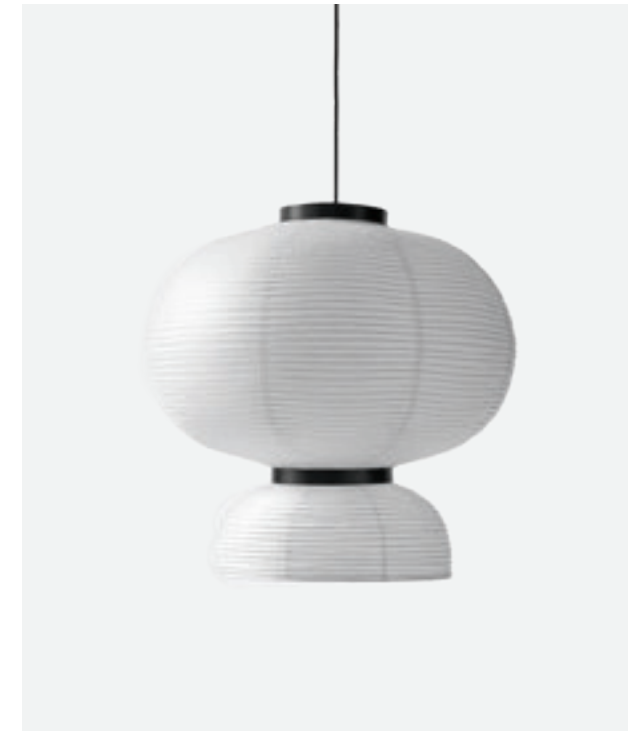
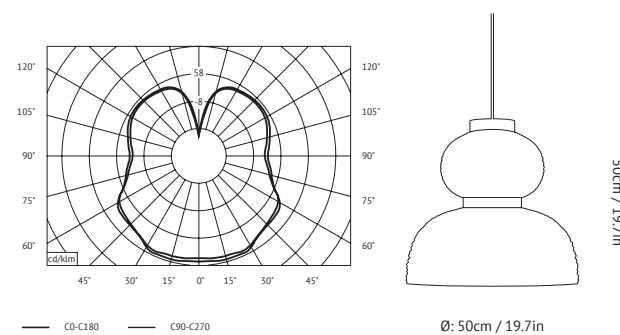

## FORMAKAMI JH5

BY JAIME HAYON  
2015

**Product category** Pendant  
**Materials** Ivory white paper, black stained oak, 4-meter black fabric cord.  
**Dimensions (cm/in)** Ø: 70cm/27.6in, H: 74cm/29.1in.  
**Colours** Ivory white paper with black stained oak.  
**Light source** E27 2 x Max 60 Watt.  
 The luminaire is compatible with bulbs of the energy classes: A++ - E. Bulb is not included.

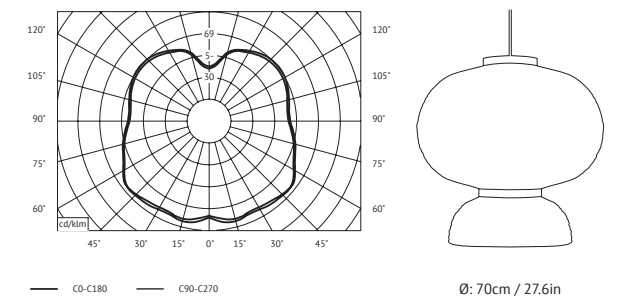

## ARRAY JK1

BY SOFIE REFER, JAKOB STAER AND  
JESPER KONGSHAUG  
2011

**Product category** Chandelier  
**Materials** Lacquered aluminium, acrylic diffuser, silicon cord.  
**Dimensions (cm/in)** Canopy: H: 55cm/21.7in, D: 26cm/10.2in, L: 5cm/1.9in. Total max length: 250cm/98.4in.  
**Colours:** Black, White.  
**Light source** 8 x built-in 2,5 Watt LED - 3000 Kelvin.  
 The luminaire is compatible with bulbs of the energy classes: A++ - A. The built-in LEDs cannot be changed in this luminaire.

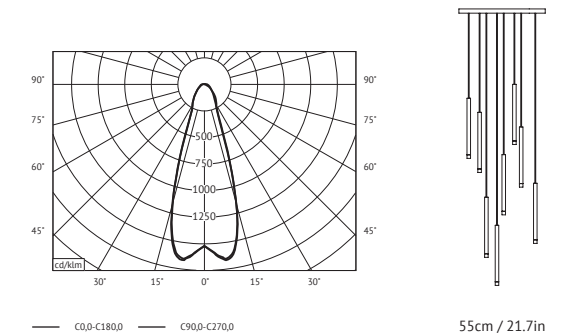





## BELLEVUE FLOOR AJ7

BY ARNE JACOBSEN  
1929

- Product category** Floor lamp  
**Materials** Satin polished brass or satin polished brass with lacquered aluminium and steel, cast iron base, 2-meter fabric cord with on-off switch.  
**Dimensions (cm/in)** Base: Ø: 27.3cm/10.7in. Lamp: D: 60cm/23.6in, H: 130cm/51.2in  
**Colours** Ivory white & brass, Brass, Grey beige & brass, Black & brass.  
**Light source** E27 Max 60 Watt. The luminaire is compatible with bulbs of the energy classes: A++ - E. Bulb is not included.

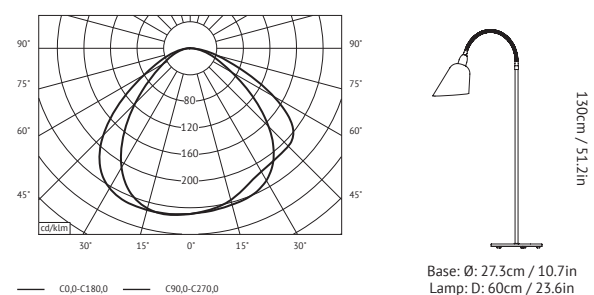

## BELLEVUE TABLE AJ8

BY ARNE JACOBSEN  
1929

- Product category** Table lamp  
**Materials** Satin polished brass or satin polished brass with lacquered aluminium and steel, cast iron base, 2-meter fabric cord. On-off switch on base.  
**Dimensions (cm/in)** Base: Ø: 17.5cm/6.9in. Lamp: D: 42cm/16.5in, W: 16.5cm/6.5in, H: 42cm/16.5in  
**Colours** Ivory white & brass, Brass, Grey beige & brass, Black & brass.  
**Light source** E14 Max 40 Watt. The luminaire is compatible with bulbs of the energy classes: A++ - E. Bulb is not included.

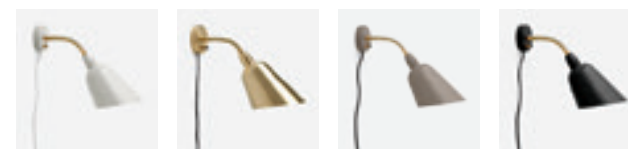
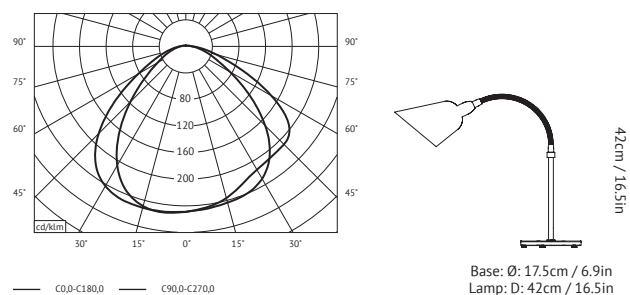

## BELLEVUE WALL AJ9

BY ARNE JACOBSEN  
1929

- Product category** Wall lamp  
**Materials** Satin polished brass or satin polished brass with lacquered aluminium and steel, 2-meter fabric cord. On-off switch on wall mount base.  
**Dimensions (cm/in)** Wall Mount: Ø: 8.5cm/3.3in. Lamp: D: 28cm/11in, W: 16.5cm/6.5in, H: 30cm/11.8in  
**Colours** Ivory white & brass, Brass, Grey beige & brass, Black & brass.  
**Light source** E14 Max 40 Watt. The luminaire is compatible with bulbs of the energy classes: A++ - E. Bulb is not included.

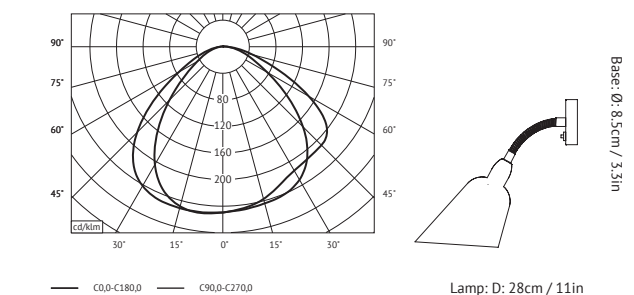

## WORKING TITLE HK1

BY HARRI KOSKINEN  
2017

- Product category** Table lamp  
**Materials** Hand polished aluminium & black PVC cord.  
**Dimensions (cm/in)** H: 45cm/17.7in, L: 30cm/11.8in, W: 15cm/5.9in.  
**Colours** Hand polished aluminium & black PVC cord.

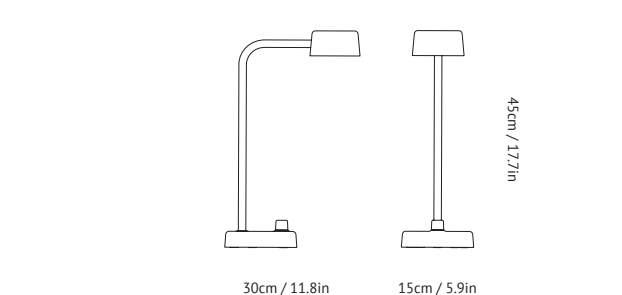

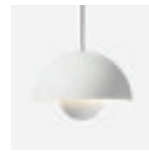
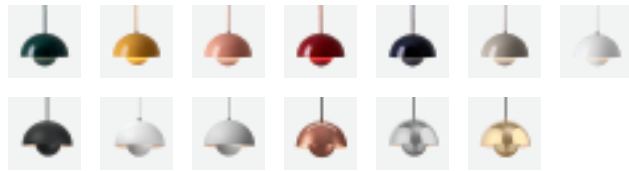
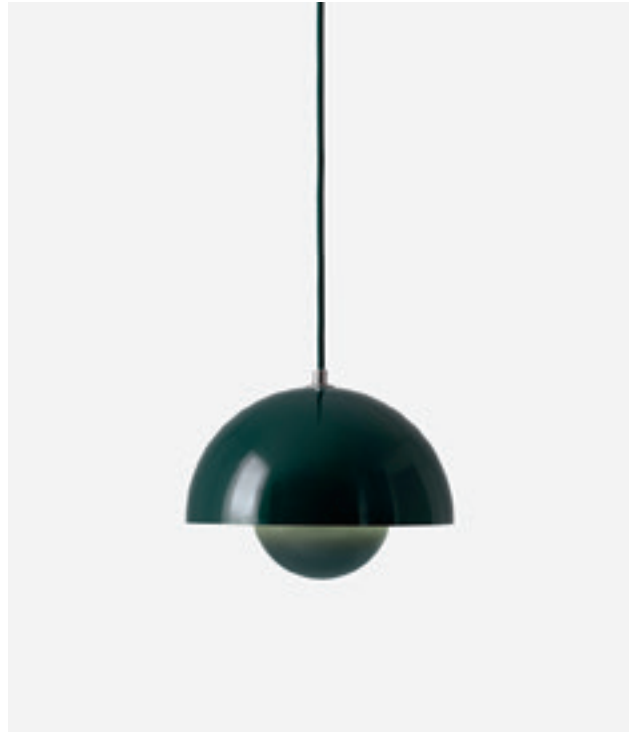

## FLOWERPOT VP1

BY VERNER PANTON  
1968

- Product category** Pendant
- Materials** Lacquered metal with 3-meter fabric cord.
- Dimensions (cm/in)** Ø: 23cm/9.1in, H: 16cm/6.3in.
- Colours** Dark green, Mustard, Beige red, Deep red, Black blue, Grey beige, White, Matt black, Matt white, Matt grey, Polished copper, Polished stainless steel, Polished brass.
- Light source** E27 Max 40 Watt. The luminaire is compatible with bulbs of the energy classes: A++ - E. Bulb is not included.

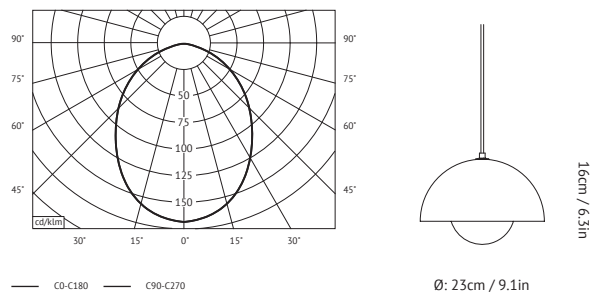

## FLOWERPOT VP2

BY VERNER PANTON  
1968

- Product category** Pendant
- Materials** Lacquered metal with 3-meter fabric cord.
- Dimensions (cm/in)** Ø: 50cm/19.7in, H: 36cm/14.2in.
- Colours** White, other colours upon request.
- Light source** E27 Max 60 Watt. The luminaire is compatible with bulbs of the energy classes: A++ - E. Bulb is not included.

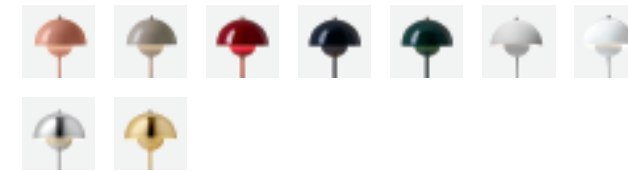
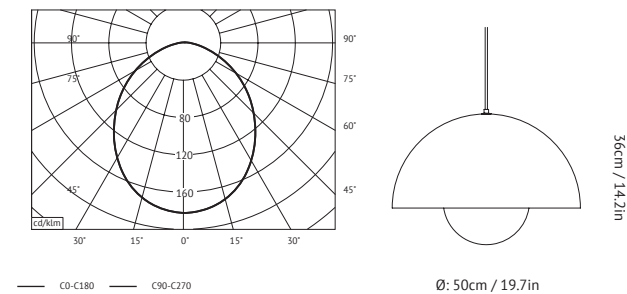

## FLOWERPOT VP3

BY VERNER PANTON  
1969

- Product category** Table lamp
- Materials** Lacquered steel with 2-meter clear PVC cord.
- Dimensions (cm/in)** Ø: 23cm/9.1in, H: 50cm/19.7in.
- Colours** Beige red, Grey beige, Deep red, Black blue, Dark green, Matt Grey, White, Polished stainless steel, Polished brass.
- Light source** E27 Max 40 Watt. The luminaire is compatible with bulbs of the energy classes: A++ - E. Bulb is not included.

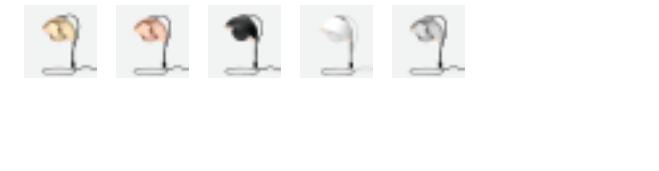
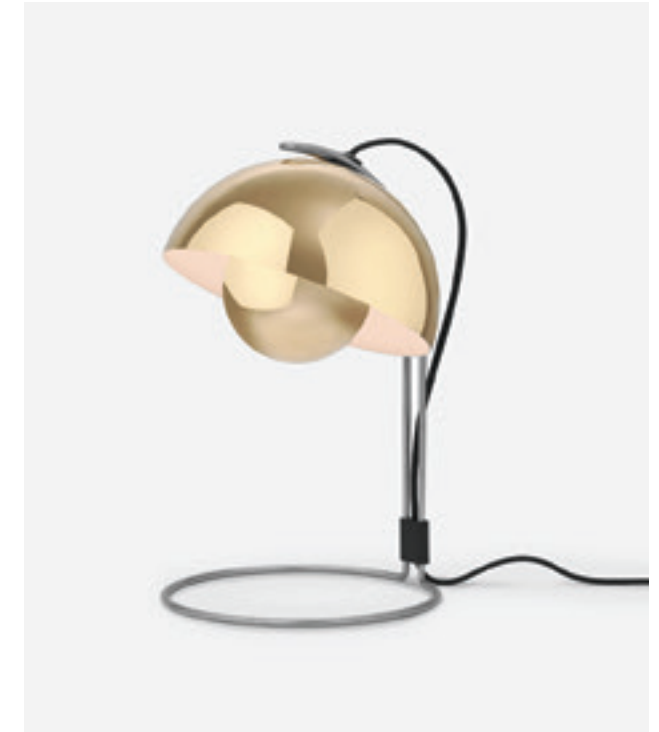
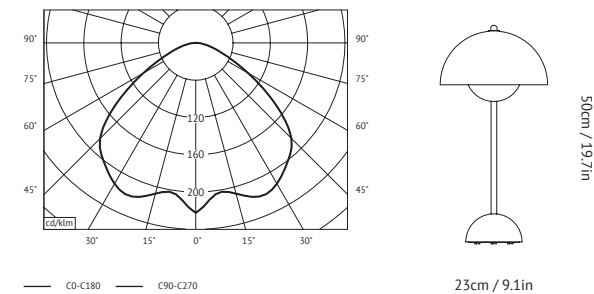

## FLOWERPOT VP4

BY VERNER PANTON  
1968

- Product category** Table lamp
- Materials** Lacquered metal with 3-meter fabric cord.
- Dimensions (cm/in)** Ø: 23cm/9.1in, H: 36cm/14.1in.
- Colours** Polished brass, Polished copper, Matt black, Matt white, Polished stainless steel.
- Light source** E 27 Max 40 Watt. The luminaire is compatible with bulbs of the energy classes: A++ - E. Bulb is not included.

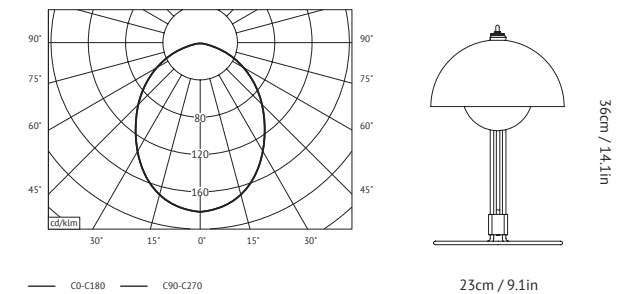

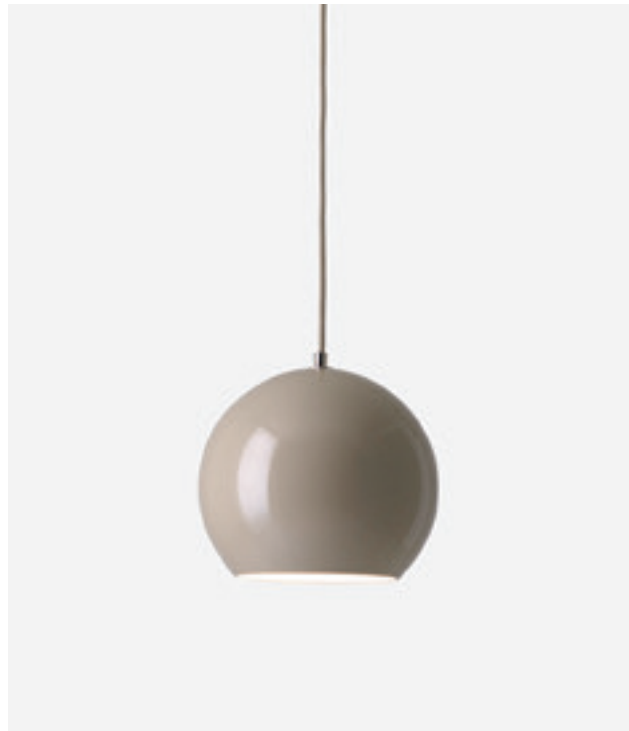

## TOPAN VP6

BY VERNER PANTON  
1959

**Product category** Pendant  
**Materials** Lacquered aluminium with 3-meter fabric cord.  
**Dimensions (cm/in)** Ø: 21cm/8.3in, H: 19cm/7.5in.  
**Colours** Grey beige, White, Black blue, Dark green, Deep red.  
**Light source** E27 Max 40 Watt. The luminaire is compatible with bulbs of the energy classes: A++ - E. Bulb is not included.

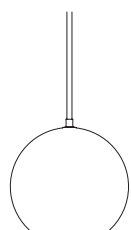
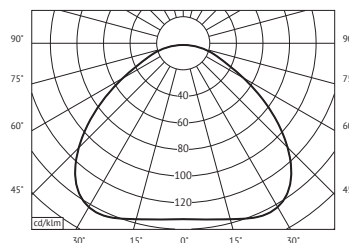

Ø: 21cm / 8.3in

19cm / 7.5in

## COPENHAGEN PENDANT SC6

BY SPACE COPENHAGEN  
2014

**Product category** Pendant  
**Materials** Lacquered steel shade with plated steel suspension or satinized opal glass shade with bronzed brass suspension, 4-meter black fabric cord.  
**Dimensions (cm/in)** Ø: 20cm/7.8in, H: 25cm/9.8in.  
**Colours** Opal glass, Matt white, Matt moss, Matt blush, Matt slate, Matt black  
**Light source** G9 Max 40 Watt. The luminaire is compatible with bulbs of the energy classes: B - E. Bulb is not included.

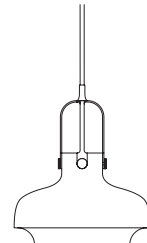
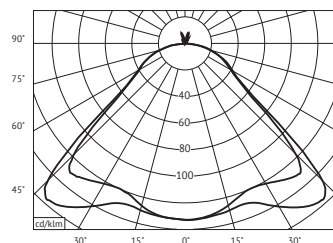

Ø: 20cm / 7.8in

25cm / 9.8in

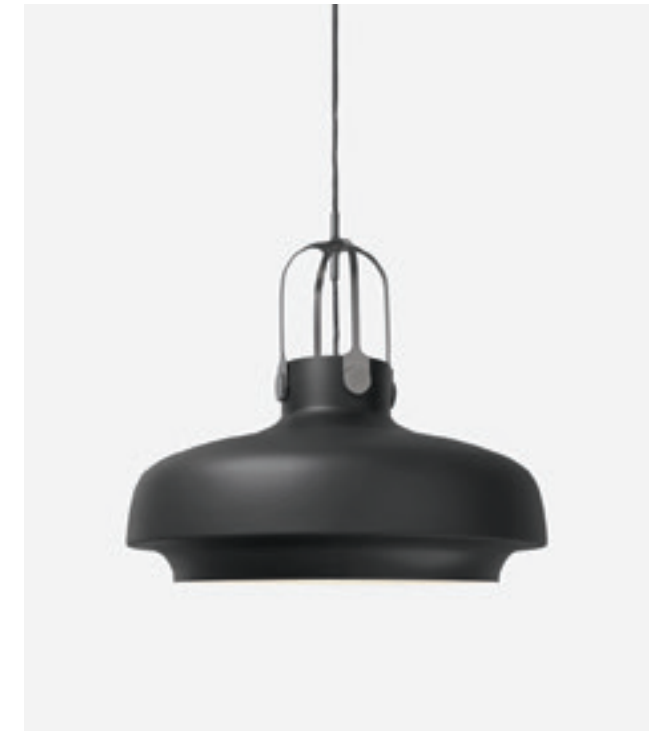
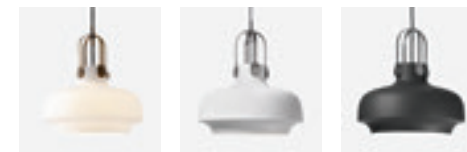
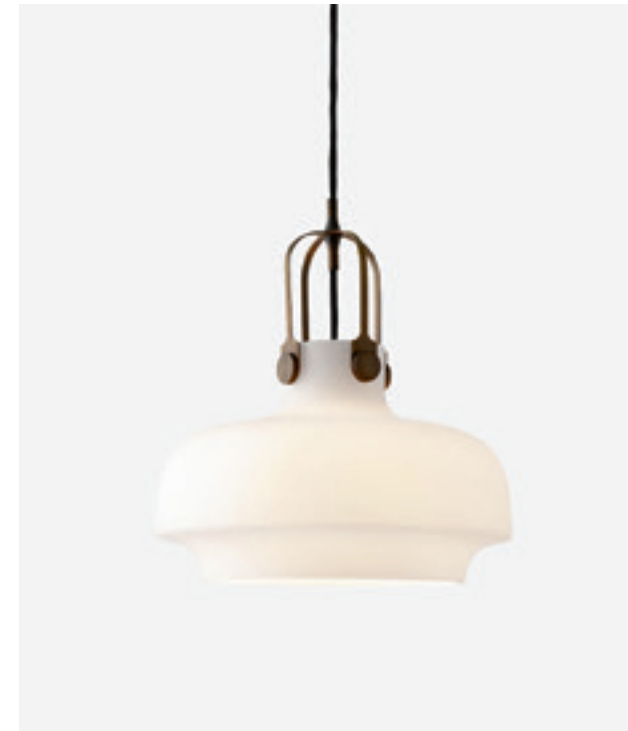

## COPENHAGEN PENDANT SC7

BY SPACE COPENHAGEN  
2014

**Product category** Pendant  
**Materials** Lacquered steel shade with plated steel suspension or satinized opal glass shade with bronzed brass suspension, 4-meter black fabric cord.  
**Dimensions (cm/in)** Ø: 35cm/13.8in, H: 40cm/15.7in.  
**Colours** Opal glass, Matt black, Matt white.  
**Light source** E27 Max 100 Watt. The luminaire is compatible with bulbs of the energy classes: A++ - E. Bulb is not included.

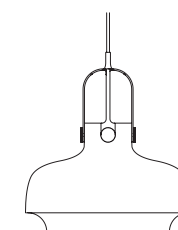
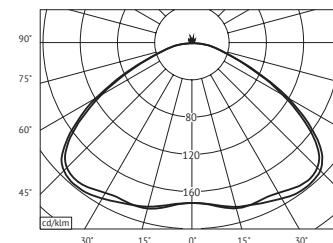

Ø: 35cm / 13.8in

40cm / 15.7in

## COPENHAGEN PENDANT SC8

BY SPACE COPENHAGEN  
2014

**Product category** Pendant  
**Materials** Lacquered aluminum shade with plated steel suspension, 6-meter fabric cord with safety wire.  
**Dimensions (cm/in)** Ø: 60cm/23.6in, H: 53cm/20.7in.  
**Colours** Matt black, Matt white.  
**Light source** E27 Max 150 Watt. The luminaire is compatible with bulbs of the energy classes: A++ - E. Bulb is not included.

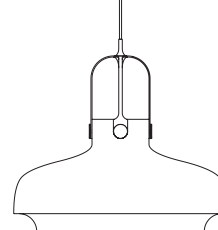
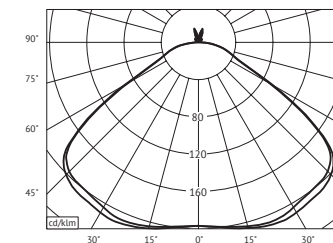

Ø: 60cm / 23.6in

53cm / 20.7in



## SPINNING LIGHT BH1

BY BENJAMIN HUBERT  
2010

**Product category** Pendant  
**Materials** Lacquered aluminium with 4-meter PVC cord.  
**Dimensions (cm/in)** H: 45cm/17.7in, Ø: 25cm/9.8in.  
**Colours** White, Matt white, Matt dark grey, Black, Matt black  
**Light source** E27 Max 60 Watt. The luminaire is compatible with bulbs of the energy classes: A++ - E. Bulb is not included.

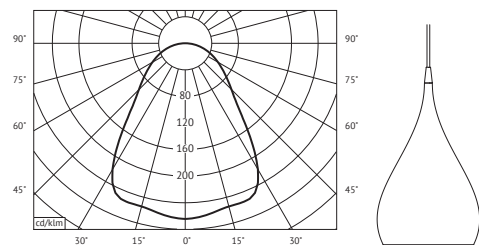

Ø: 25cm / 9.8in

## SPINNING LIGHT BH2

BY BENJAMIN HUBERT  
2010

**Product category** Pendant  
**Materials** Lacquered aluminium with 4-meter PVC cord.  
**Dimensions (cm/in)** Ø: 40cm/15.7in, H: 34cm/13.4in.  
**Colours** White, Matt white, Matt dark grey, Black, Matt black  
**Light source** E27 Max 60 Watt. The luminaire is compatible with bulbs of the energy classes: A++ - E. Bulb is not included.

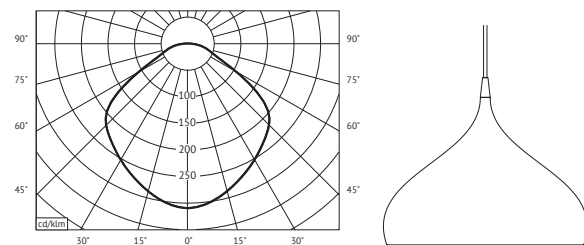

Ø: 40cm / 15.7in

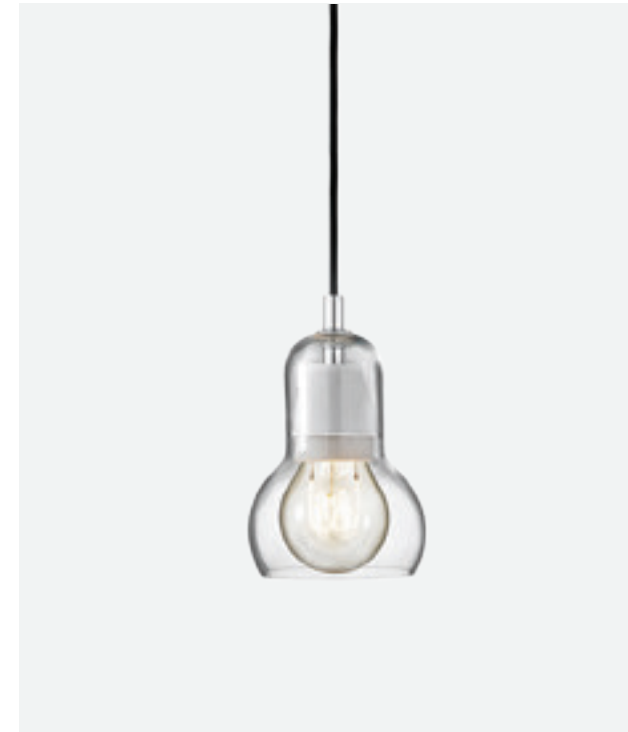

## BULB SR1

BY SOFIE REFER  
2001

**Product category** Pendant  
**Materials** Mouth blown glass with 3-meter cord and porcelain lamp holder.  
**Dimensions (cm/in)** Ø: 11cm/4.3in, H: 16.3cm/6.4in.  
**Colours** Clear glass with clear PVC cord, Clear glass with black fabric cord.  
**Light source** E27 Max 60 Watt. The luminaire is compatible with bulbs of the energy classes: A++ - E. Bulb is not included.

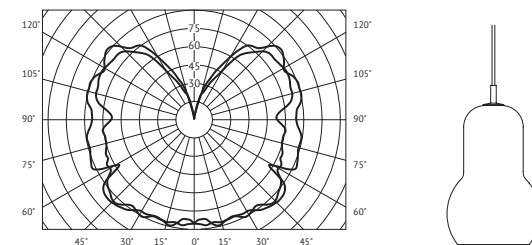

Ø: 11cm / 4.3in



## MEGA BULB SR2

BY SOFIE REFER  
2006

**Product category** Pendant  
**Materials** Mouth blown glass with 3-meter cord and porcelain lamp holder.  
**Dimensions (cm/in)** Ø: 18cm/7.1in, H: 23cm/9in.  
**Colours** Clear glass with black fabric cord, Clear glass with clear cord, Silver lustre glass with black fabric cord, Silver lustre glass with clear PVC cord, Gold lustre glass with white fabric cord, Gold lustre glass with clear PVC cord.  
**Light source** E27 Max 60 Watt. The luminaire is compatible with bulbs of the energy classes: A++ - E. Bulb is not included.

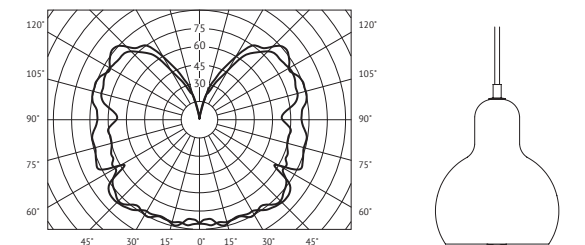

Ø: 18cm / 7.1in

— C0-C180 — C90-C270

— C0-C180 — C90-C270

— C0-C180,0 — C90-C270,0

— C0-C180,0 — C90-C270,0

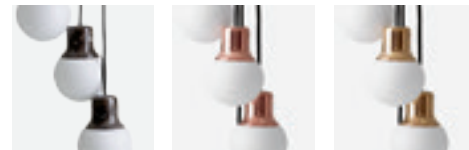
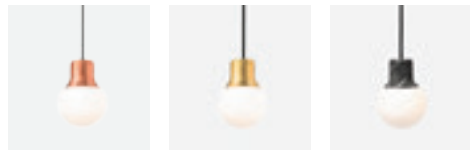
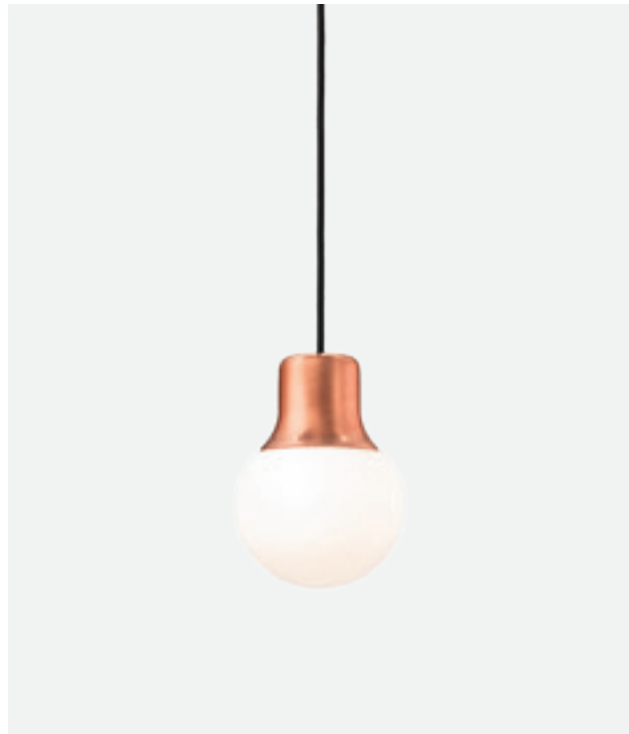

## MASS LIGHT NA5

BY NORM.ARCHITECTS  
2012

**Product category** Pendant  
**Materials** Marble, copper or brass, white acid-etched opal glass, 4-meter black fabric cord. Mass Light can also be bought as a chandelier with a canopy for 9 pendants.  
**Dimensions (cm/in)** Ø: 12.6cm/5in, H: 18.3cm/7.2in.  
**Light Source** G9 Max 40 Watt. The luminaire is compatible with bulbs of the energy classes: B - E. Bulb is not included.

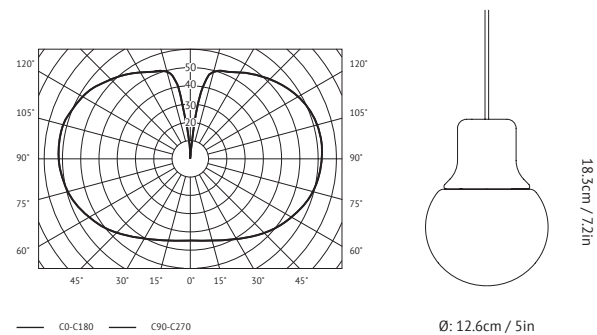

## MASS LIGHT NA6

BY NORM.ARCHITECTS  
2012

**Product category** Chandelier  
**Materials** Marble, copper or brass, white acid-etched opal glass, 4-meter black fabric cord.  
**Dimensions (cm/in)** Ø: 12.6cm/5in, H: 18.3cm/7.2in, L: Min 80cm/31.5in Max 175cm/68.9in. W: 40cm/15.7in. Base: 16cm.  
**Light source** 1 x G9 – max 40 Watt.  
**Lamps included** G9 Max 40 Watt. The luminaire is compatible with bulbs of the energy classes: B - E. Bulb is not included.

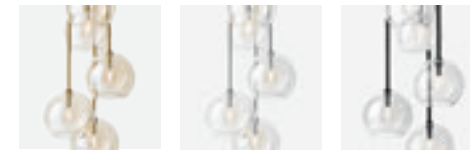
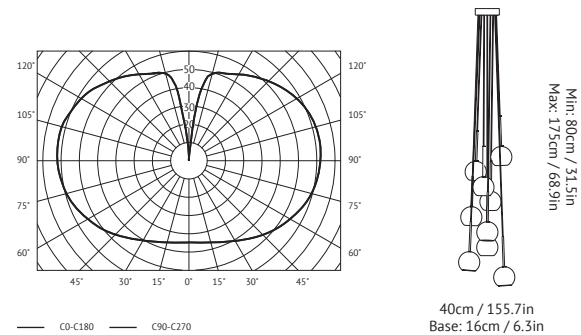

## ICE CHANDELIER SR6-SR10

BY SOFIE REFER  
2006

**Product category** Chandelier  
**Materials** Mouth-blown glass and anodised aluminium with clear PVC cord.  
**Dimensions (cm/in)** SR6: Ø: 38cm/14.9in, L: 180cm/70.8in. Custom sizes available upon request.  
**Colours** Clear glass with anodized aluminium. Silver lustre glass with black anodized aluminium. Gold lustre glass with gold anodized aluminium.  
**Light source** 9 x G4 Max 10 Watt. The luminaire is compatible with bulbs of the energy class: C. The luminaire is sold with a bulb of the energy class: C.

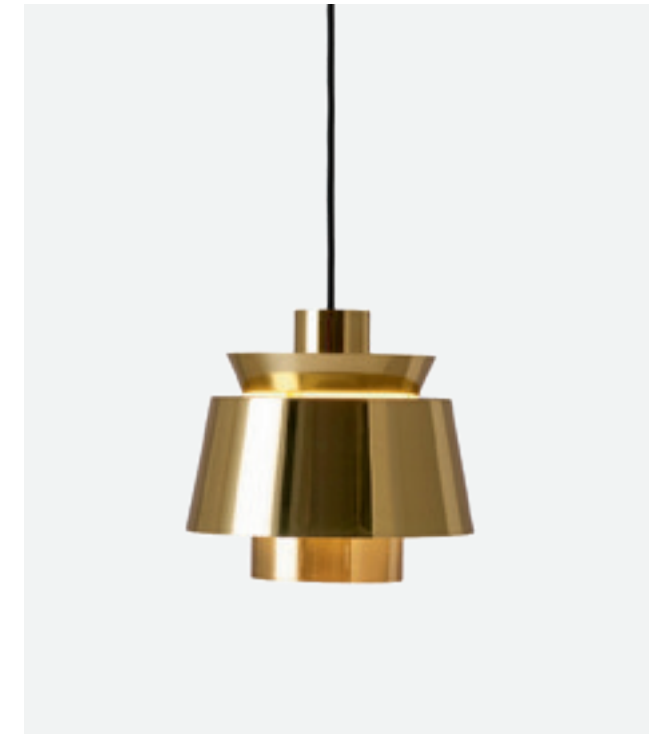
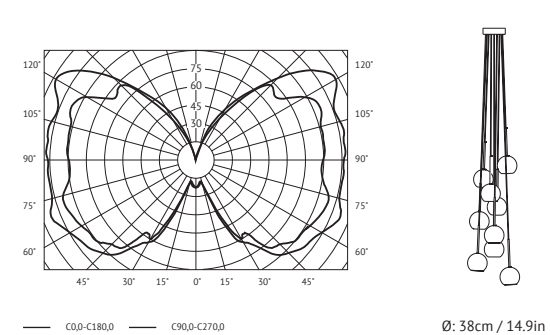

## UTZON LAMP JU1

BY JØRN UTZON  
1947

**Product category** Pendant  
**Materials** Lacquered metal, 3-meter fabric cord.  
**Dimensions (cm/in)** Ø: 22cm/8.7in, H: 23cm/9.1in.  
**Colours** White lacquered steel with white fabric cord, brass with black fabric cord, lacquered copper with black fabric cord.  
**Light source** E27 Max 60 Watt. The luminaire is compatible with bulbs of the energy classes: A++ - E. Bulb is not included.

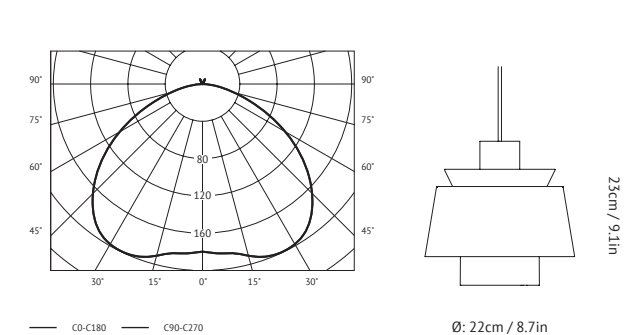



## TRASH ME VV1

BY VICTOR VETTERLEIN  
2010

**Product category** Table lamp  
**Materials** Paper pulp, 2-meter bordeaux fabric cord.  
**Dimensions (cm/in)** H: 52.4cm/20.6in, L: 25.4cm/10in, W: 16.5cm/6.5in.  
**Cord Colours** Natural paper bordeaux fabric colour.  
**Light Source:** E27 Max 40 Watt. The luminaire is compatible with bulbs of the energy classes: A++ - E. Bulb is not included.

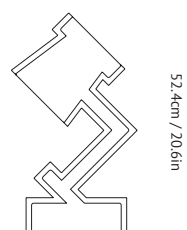
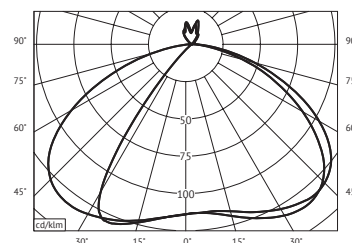

25.4cm / 10in x 16.5cm / 6.5in



&tradition  
 Papirøen, Trangravsvej 24  
 DK - 1436 Copenhagen K  
 andtradition.com

©&tradition 2017

#andtradition

CONCEPT / CREATIVE DIRECTION  
 All the Way to Paris

ARTICLES  
 Julie Ralphs

PHOTOGRAPHY  
 Irina Boersma & Peter Krasilnikoff  
 Brian Buchard  
 Mikkel Rahr Mortensen

GRAPHIC DESIGN  
 All the Way to Paris

PRINTED AT  
 Narayana Press

