



Furniture

Pezzi unici, veri e propri elementi di arredo che contribuiscono a formare lo spirito dei luoghi che li accolgono • A collection of unique and functionally designed elements that help to shape the mood of the environments in which we live • Pièces uniques, véritables éléments fondamentaux d'ameublement qui contribuent à former l'esprit des lieux qui les accueillent • Einzelstücke, fundamentale Möbelemente, die dazu beitragen, den Geist der Räumlichkeiten, die sie aufnehmen, zu bilden • Piezas únicas, elementos fundamentales de decoración que contribuyen formando el espíritu de los lugares que los acogen.

Furnishing accessories

Trasparenze senza tempo che si inseriscono silenziosamente in ambienti anche molto diversi tra loro, grazie a linee purissime e eleganti • Timeless objects that fit unobtrusively into a wide variety of interiors due to their pure and elegant lines • Transparences sans âge qui s'insèrent silencieusement dans des lieux très différents les uns des autres, grâce à des lignes très pures et élégantes • Zeitlose Transparenzen, die sich dank ihrer reinen und eleganten Linien geräuschlos in sehr unterschiedlichen Räumlichkeiten einfügen • Transparencias intemporales que se integran silenciosamente en una amplia variedad de interiores, gracias a sus líneas purísimas y elegantes.

Teso

Renzo Piano 1985



Tavolo. Piano in vetro float stratificato (spessore 25 mm). Gambe in lastre di vetro float stratificato, dello spessore di 38 mm, con scanalature per inserimento di tiranti in metallo. La tensione, grazie all'elevato coefficiente di compressione del vetro, trasforma il tavolo in un monoblocco.

Table. Layered (25 mm thick) float-glass top. Layered (38 mm thick) float-glass sheet legs, grooved to contain metal ties. Thanks to its high glass-compression coefficient, tension makes the table a one-piece structure.

Table. Plateau en verre float stratifié (épaisseur 25 mm). Pieds en plaque de verre float stratifié (épaisseur 38 mm) rainurés pour l'introduction de tirants en métal. Grâce au coefficient de compression élevé du verre, la tension transforme la table en un monobloc.

Tisch. Oberfläche aus geschichtetem Float-Glas, 25 mm stark. Tischbeine aus geschichtetem Float-Glasscheiben, 38 mm stark, mit Aussparungen zum Montieren der Spannstäbe aus Metall. Durch den Druck, der durch den hohen Kompressionskoeffizienten ausgeübt wird, wirkt der Tisch wie ein einziger großer Block.

Mesa. Sobre de cristal float estratificado (espesor 25 mm). Patas en láminas de cristal float estratificado (espesor 38 mm) con ranuras para introducir tirantes de metal. La tensión, debido al importante coeficiente de compresión del cristal, transforma la mesa en un sólo bloque.

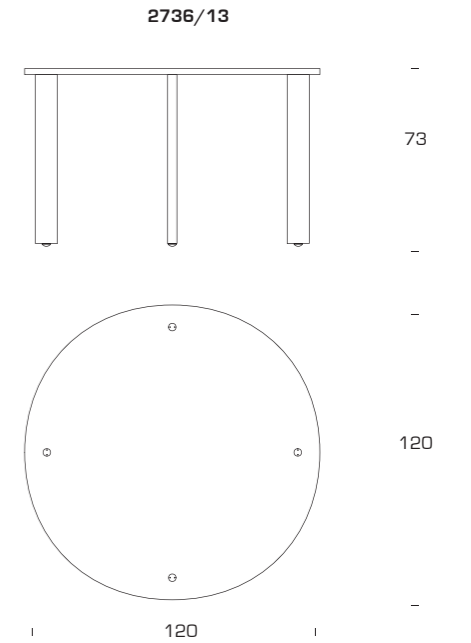
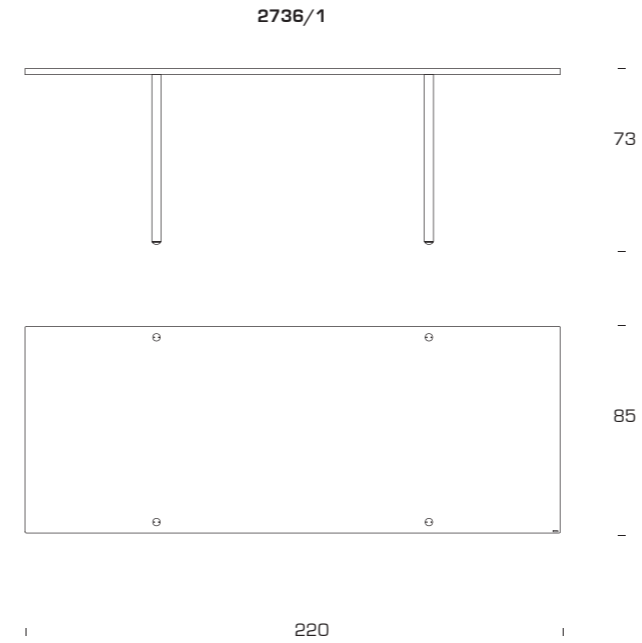

2736/1	220 x 85 x 73
2736/13	∅ 120 x 73

Tour

Gae Aulenti 1993



75

120

120

Tavolo. Piano in vetro float molato (spessore 15 mm). Ruote pivotanti fissate al piano mediante quattro piattelli in acciaio inox. Forcelle cromate. Copertoni in gomma piena.

Table. Float ground glass top (15 mm thick). Rotating wheels fixed to the top by four stainless steel plates. Chromium-plated brackets. All-rubber wheels.

Table. Plateau en verre float biseauté, (épaisseur 15 mm). Roues pivotantes fixées au plateau par quatre rondelles en acier inox. Fourches chromées. Pneumatiques en caoutchouc plein.

Tisch. Oberfläche aus geschliffenem Float-Glas (15 mm stark). Die Pivot-Räder sind mittels vier Scheiben aus Edelstahl an der Tischfläche befestigt. Verchromte Gabeln. Die Reifendecken sind aus Vollgummi.

Mesa. Sobre de cristal float biselado (espesor 15 mm). Ruedas pivotantes fijadas en el sobre con cuatro platos de acero inoxidable. Horquillas cromadas. Cubiertas de caucho denso.

3005

120 x 120 x 75

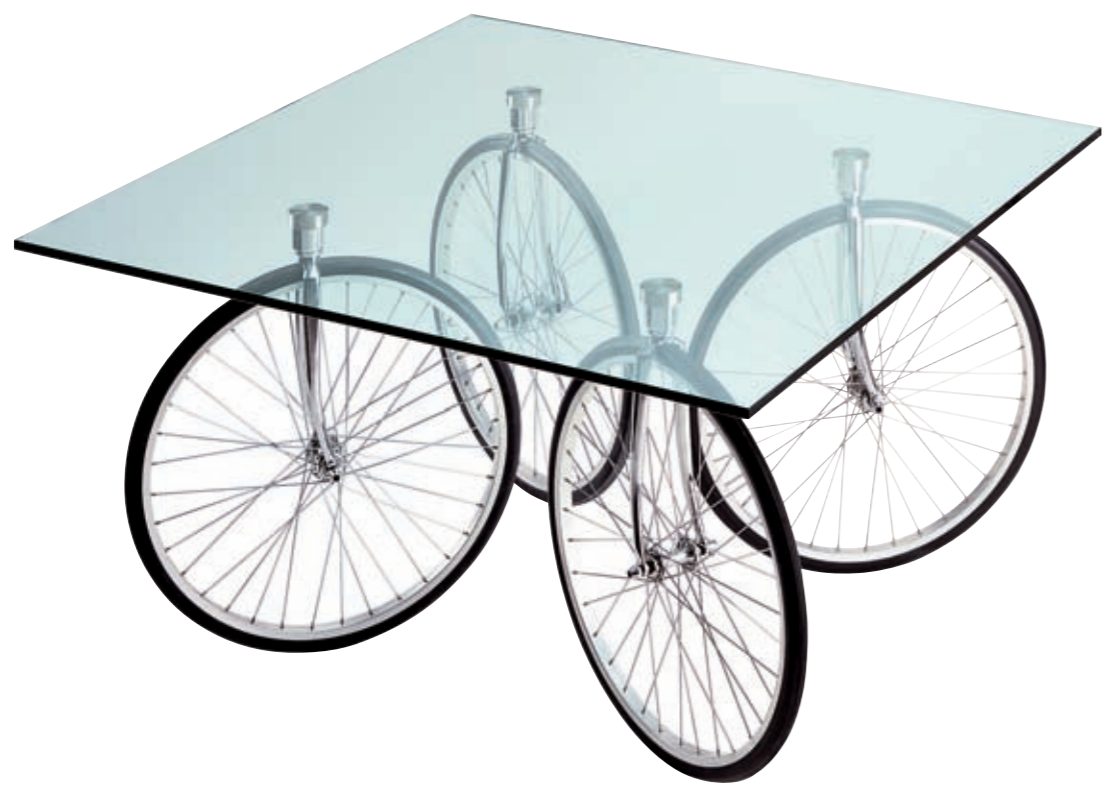

2633

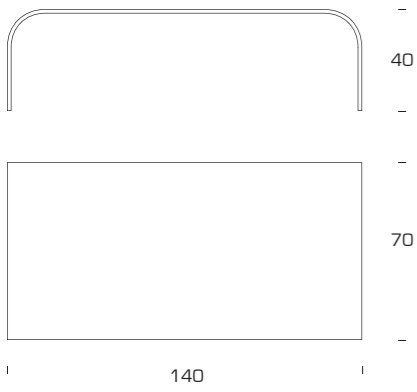

2633/1

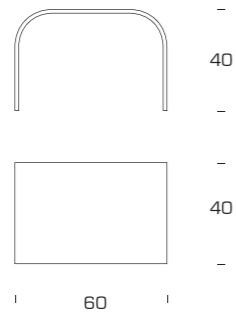

2633/2

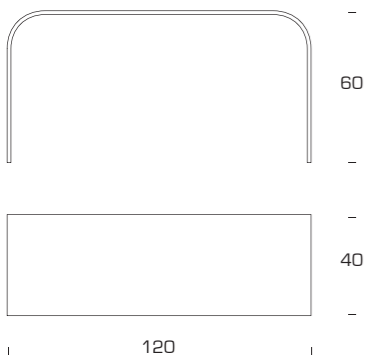

2633/4

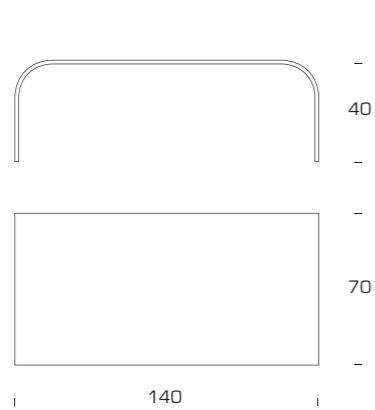

Tavolino in vetro float dello spessore di 15 mm, curvato e molato.

Coffee table. Curved and ground float-glass (15 mm thick).

Table basse en verre float (épaisseur 15 mm), courbé et biseauté.

Kleiner Tisch aus Float-Glas (15 mm stark), gebogen und geschliffen.

Mesita de cristal float (espesor 15 mm), curvado y biselado.

2633	140 x 70 x 40
2633/1	60 x 40 x 40
2633/2	120 x 40 x 60
2633/4	120 x 60 x 40

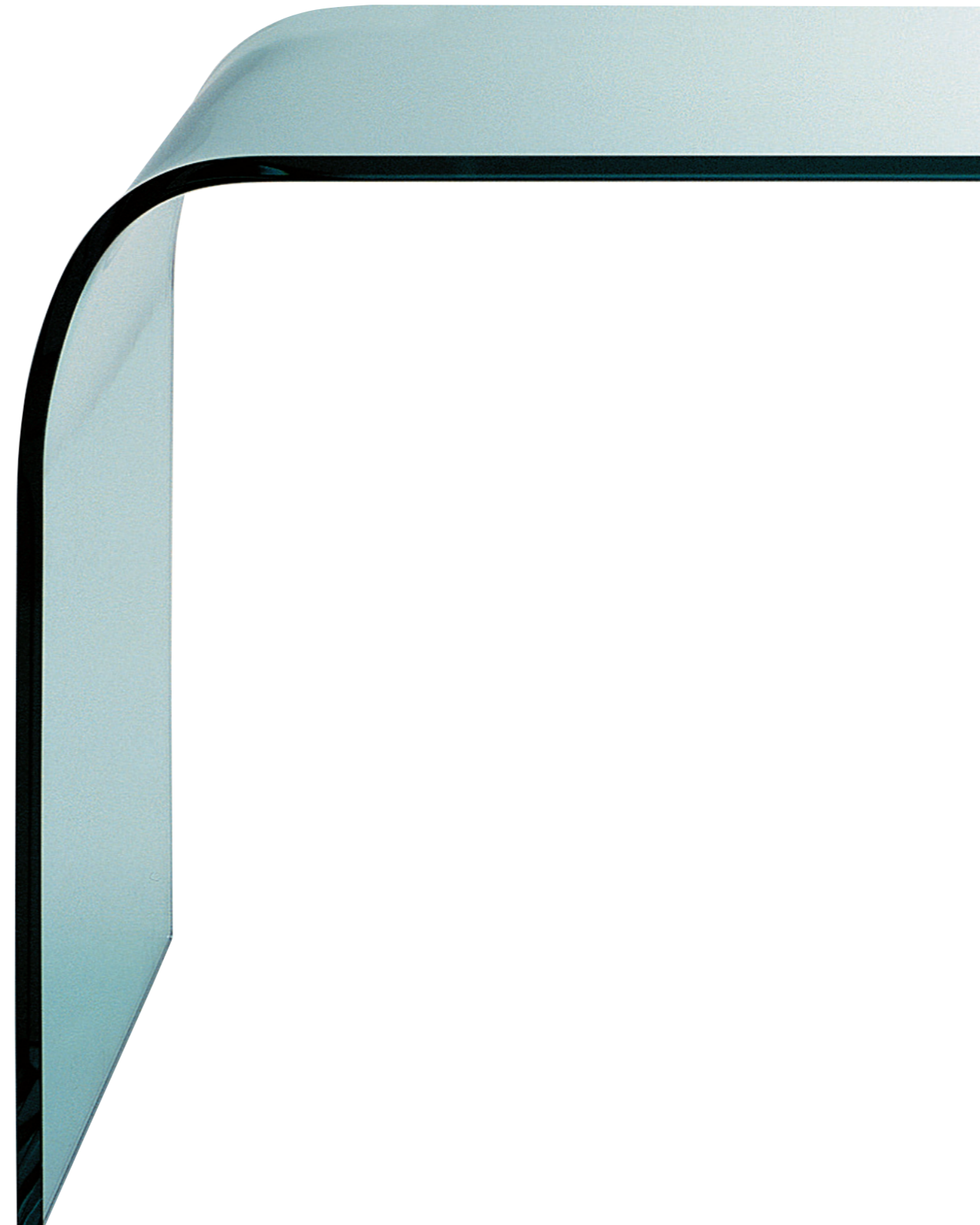
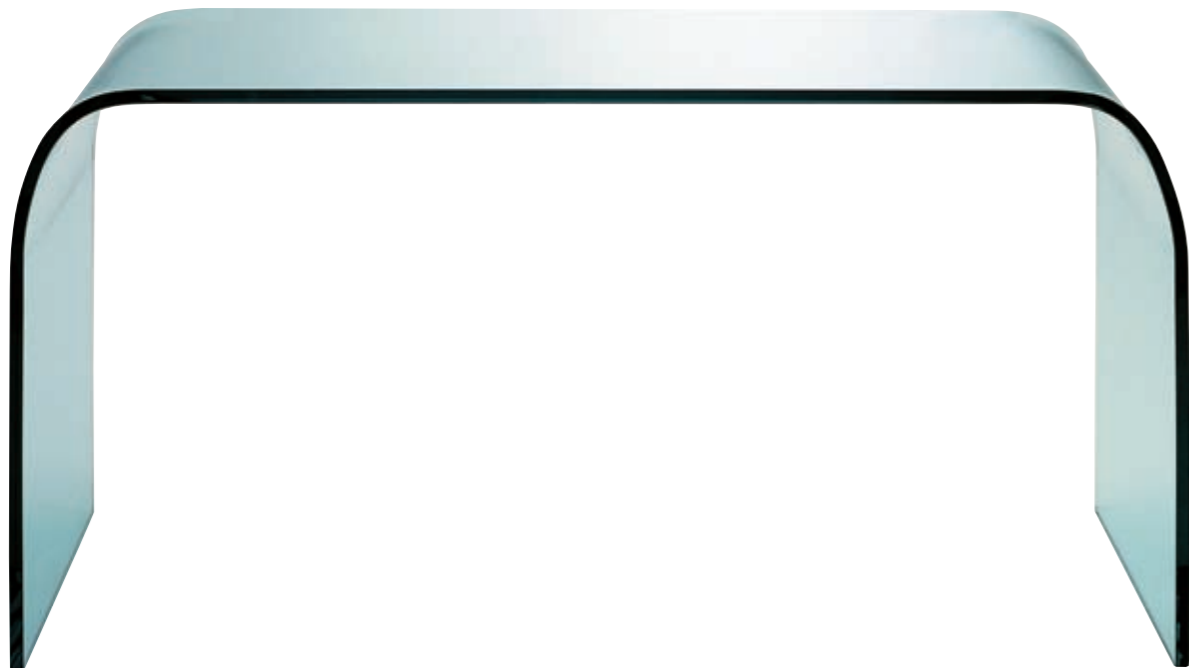

Tavolino 1932

Gio Ponti 1932

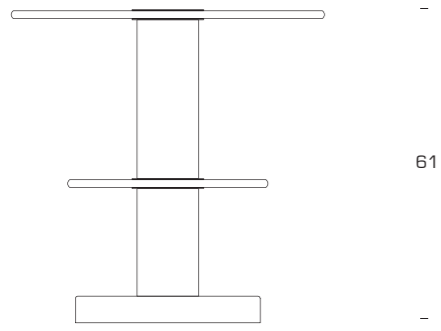

61

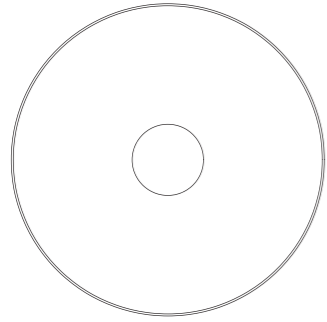

61

Tavolino con due dischi in vetro float dello spessore di 15 mm. Struttura in ottone nichelato e spazzolato.

Occasional table with two 15 mm thick float-glass disks. Structure in polished nickel-plated brass.

Table basse avec deux disques en verre float, épaisseur 15 mm. Structure en laiton nickelé et brossé.

Kleiner Tisch mit zwei runden Platten aus Float-Glas, 15 mm stark. Struktur aus geglänztem, vernickeltem Messing.

Mesita con dos discos de cristal float, espesor 15 mm. Estructura de latón niquelado y cepillado.

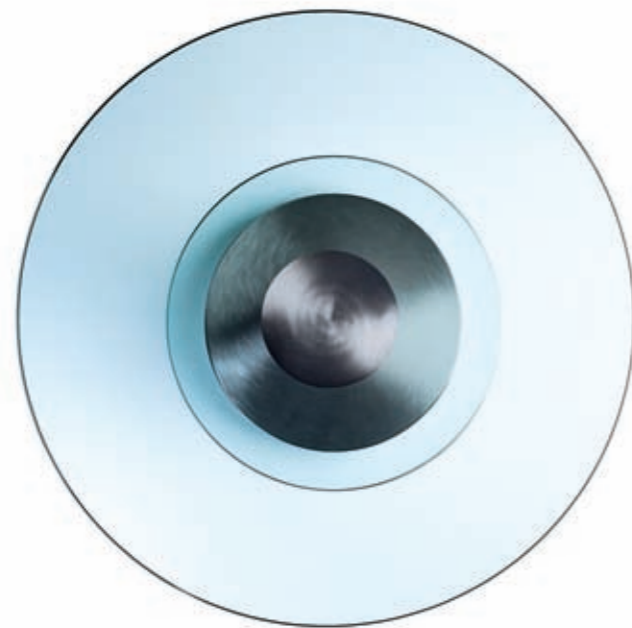

2747

∅ 61 x 61

Tavolo con Ruote

Gae Aulenti 1980

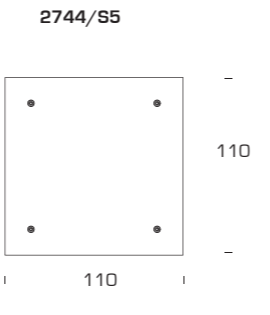
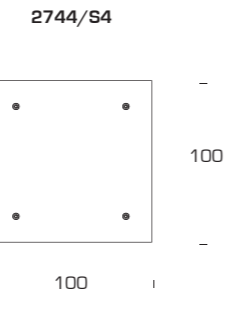
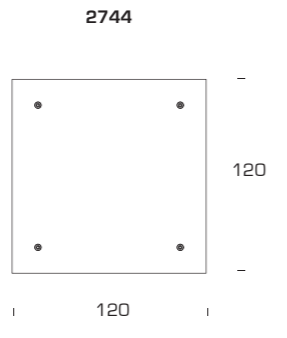
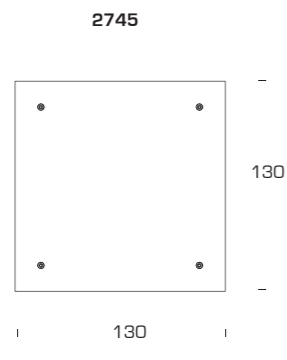
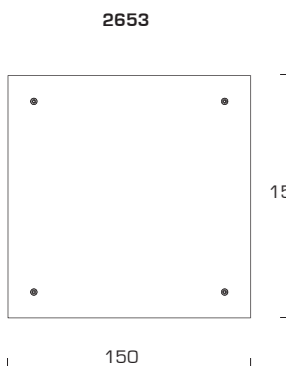
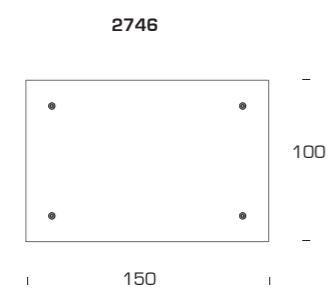
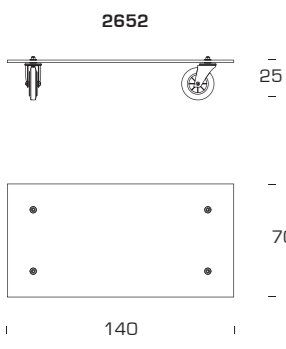

Tavolino. Piano in vetro float molato dello spessore di 15 mm. Ruote industriali con forcelle in metallo verniciato nero ottico.

Coffee table. Float ground-glass top (15 mm thick). Industrial wheels with black-painted metal brackets.

Table basse. Plateau en verre float biseauté (épaisseur 15 mm). Roulettes industrielles avec fourches en métal verni noir optique.

Kleiner Tisch. Oberfläche aus geschliffenem Float-Glas (15 mm stark). Industrieräder mit Gabeln aus optischem schwarzem lackiertem Metall.

Mesa baja. Sobre de cristal float biselado (espesor 15 mm). Ruedas industriales con horquillas de metal pintado negro óptico.

2652	140 x 70 x 25
2653	150 x 150 x 25
2744	120 x 120 x 25
2745	130 x 130 x 25
2746	150 x 100 x 25
2744/S4	100 x 100 x 25
2744/S5	110 x 110 x 25

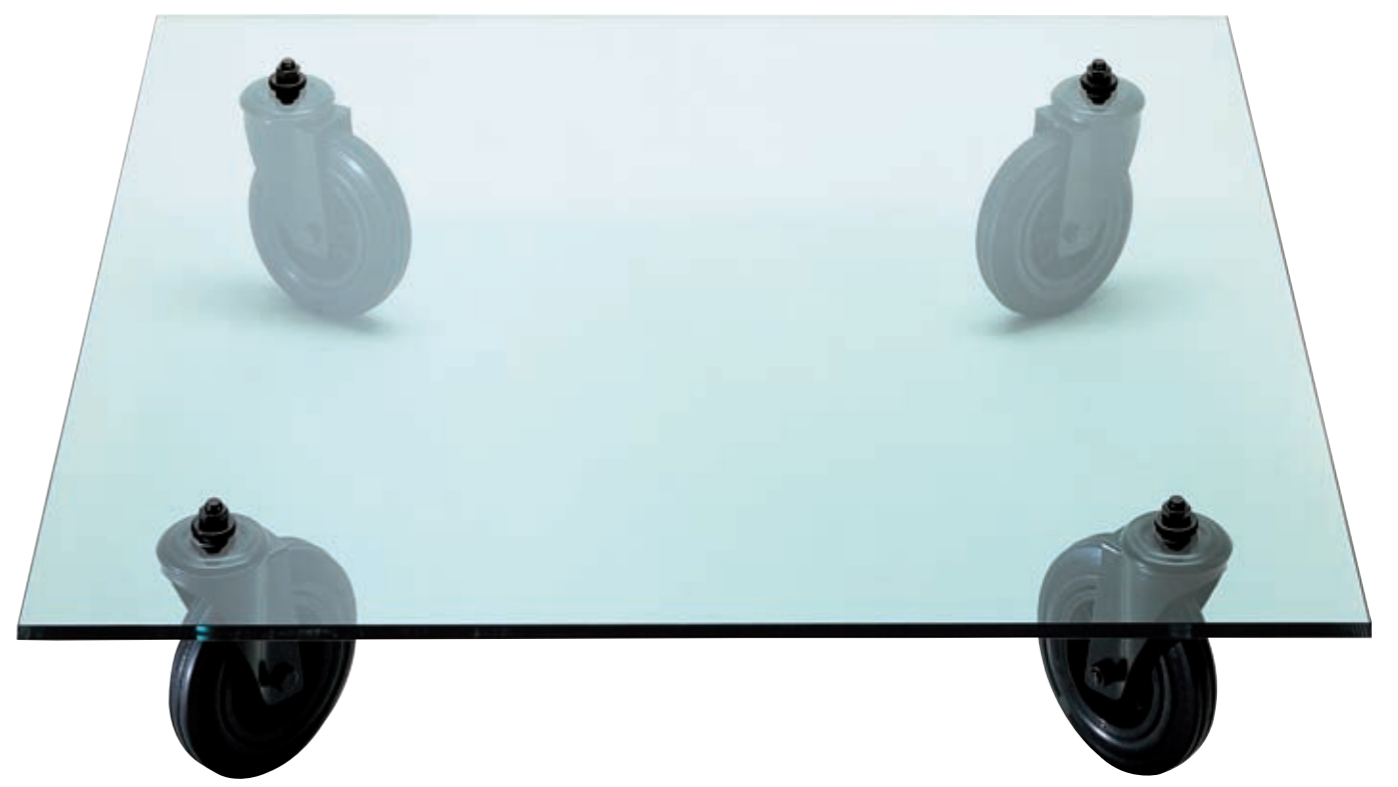

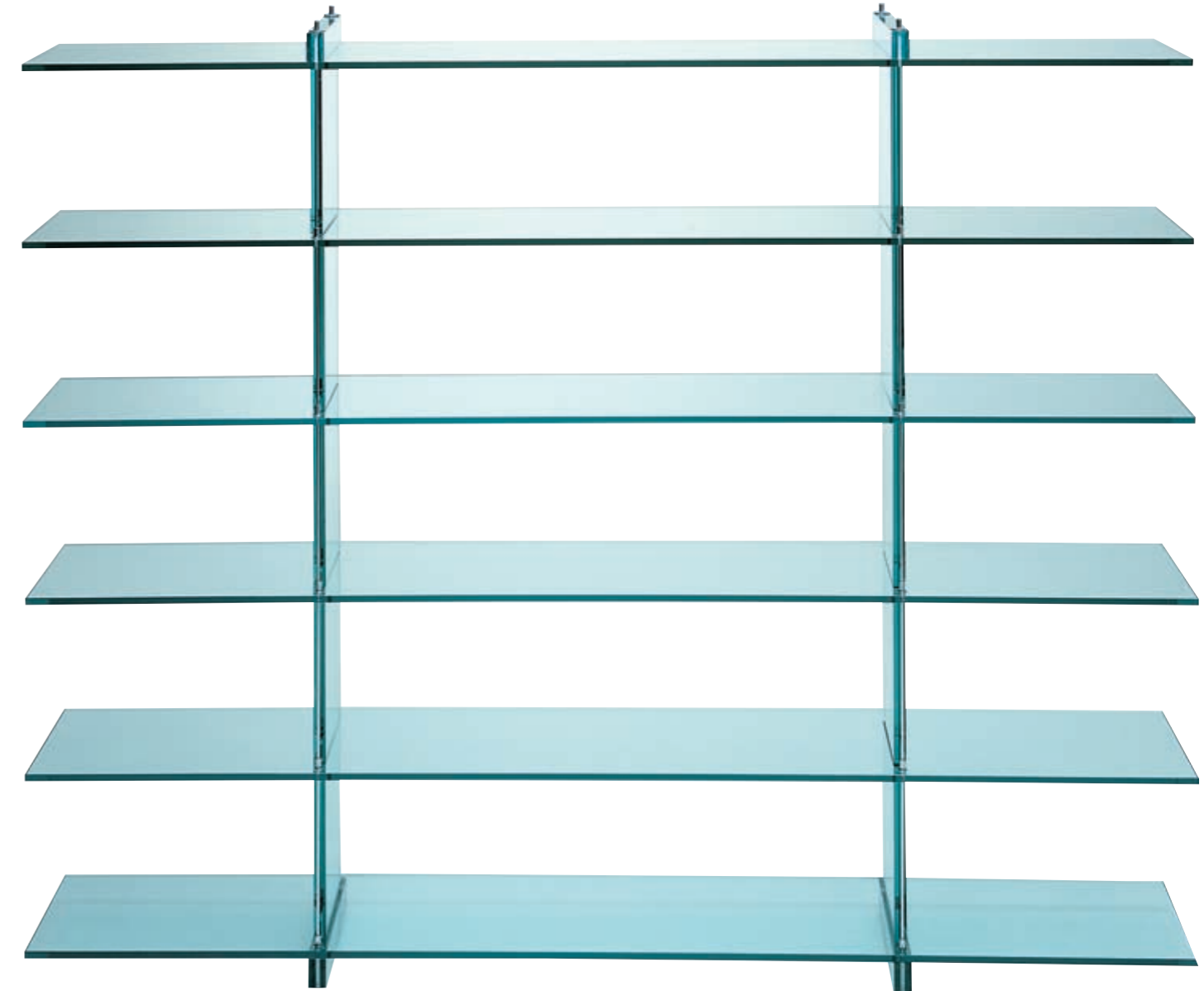
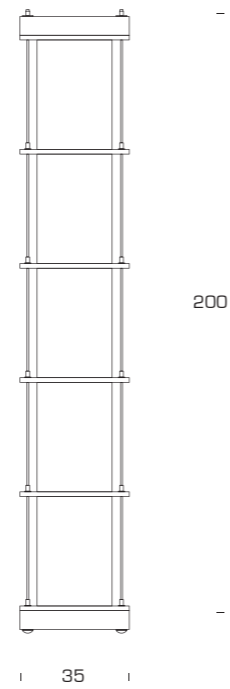
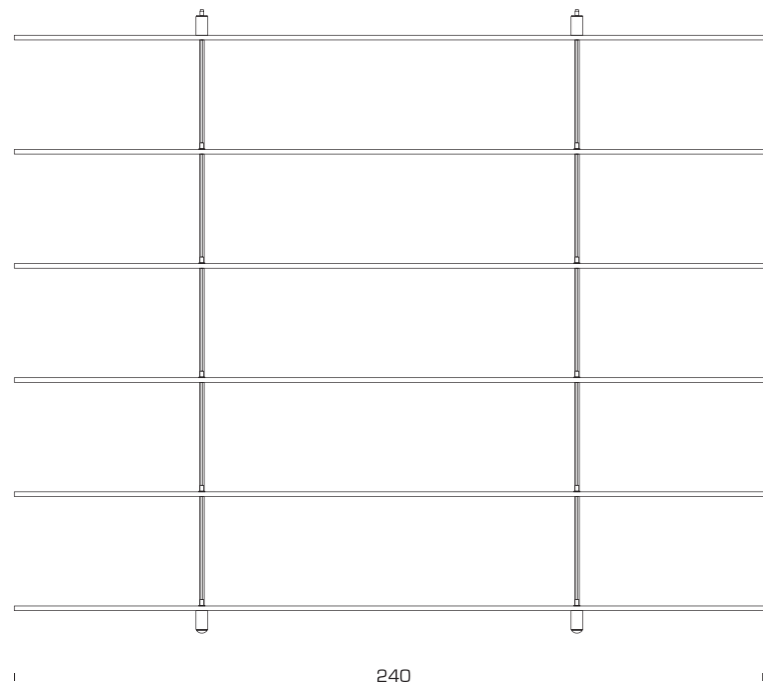

Libreria aperta sui due lati. Ripiani e montanti in vetro float dello spessore rispettivamente di 15 mm e 25 mm. Tiranti in metallo cromato. La tensione, grazie all'elevato coefficiente di compressione del vetro, trasforma la libreria in un monoblocco.

Bookcase open on two fronts. Shelves and uprights made of respectively 15 mm and 25 mm thick float-glass. Chromed metal ties. Due to the high-compression coefficient, the tension makes the bookcase a single block.

Bibliothèque ouverte sur deux fronts. Étagères (épaisseur 15 mm) et montants (épaisseur 25 mm) en verre float. Tirants en métal chromé. Grâce au coefficient de compression élevé du verre, la tension transforme l'ensemble en un monobloc.

Auf beiden Seiten offenes Bücherregal. Fächer und Pfosten aus Float-Glas 15mm bzw. 25mm hoch. Spannstangen aus verchromten Metall. Dank des hohen Kompressionskoeffizienten, wird aus dem Bücherregal ein einziger Glasblock.

Estantería abierta en dos frentes. Estantes y montantes de cristal float (espesor en respectivo 15 mm y 25 mm). Tirantes de metal cromado. La tensión, debido al importante coeficiente de compresión del cristal, transforma la estantería en un sólo bloque.

2757/6

240 x 35 x 200



Teso

Renzo Piano 1991

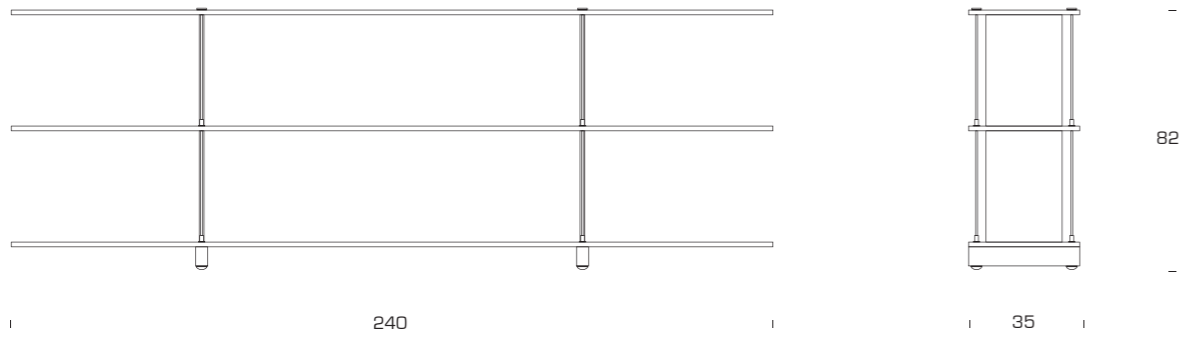

Consolle aperta sui due lati. Ripiani e montanti in vetro float dello spessore rispettivamente di 15 mm e 25 mm. Tiranti in metallo cromato. La tensione, grazie all'elevato coefficiente di compressione del vetro, trasforma la consolle in un monoblocco.

Console open on two fronts. Shelves and uprights made of respectively 15 mm and 25 mm thick float-glass. Due to the high-compression coefficient, the tension makes the console a single block.

Console ouverte sur deux fronts. Étagères (épaisseur 15 mm) et montants (épaisseur 25 mm) en verre float. Tirants en métal chromé. Grâce au coefficient de compression élevé du verre, la tension transforme l'ensemble en un monobloc.

Auf beiden Seiten offenes Regal. Fächer und Pfosten aus Float-Glas 15mm bzw. 25mm hoch. Spannstangen aus verchromten Metall. Dank des hohen Kompressionskoeffizienten, wird aus dem Regal ein einziger Glasblock.

Consola abierta en dos frentes. Estantes y montantes de cristal float (espesor en respectivo 15 mm y 25 mm). Tirantes de metal cromado. La tensión, debido al importante coeficiente de compresión del cristal, transforma la consola en un sólo bloque.

2842 240 x 35 x 82



Aixo Mateix

Valérie Bergeron 1994



Appendiabiti da parete con struttura in acciaio armonico. Sfere in vetro blu cobalto (BC), rosso rubino (R), verde (V) o trasparente (TR).

Wall coat hook with frame in harmonic steel. Spheres in cobalt blue (BC), ruby red (R), green (V) or transparent (TR) glass.

Portemanteau mural, structure en acier harmonique. Sphères en verre bleu cobalt (BC), rouge rubis (R), vert (V) ou transparent (TR).

Kleiderständern it Struktur aus harmonischem Stahl. Kugeln aus kobaltblauem (BC), rubinrotem (R), grünem (V) oder transparentem (TR) Glas.

Colgador de pared con estructura de acero armónico. Esferas de cristal azul cobalto (BC), rojo rubí (R), verde (V) o transparente (TR).



3037..BC - R - V - TR 7 x 9 x 7

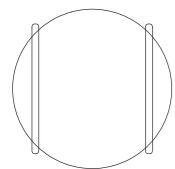

7

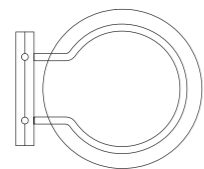

9

-
7
-

Bowl
Paolo Ulian 2003



Portaoggetti
appendiabiti in vetro
soffiato trasparente.
Gancio supplementare
per appendiabiti in metallo
cromato.

Holder and coat-hook.
Blown transparent glass.
Additional hook for
coat-stand in chrome-
plated metal.

Portemanteau et
porte-objets en verre
soufflé transparent.
Crochet supplémentaire
pour portemanteau en
métal chromé.

Kleiderständeru nd
Objektablage aus
mundgeblasenem Glas,
transparent. Zusätzlicher
Haken für Kleiderständer
aus verchromtem Metall.

Porta-objetos y colgador
de cristal soplado
transparente. Gancho
suplementario para
colgador de metal
cromado.

3411

19 x 12 x 22

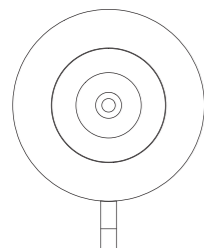

19

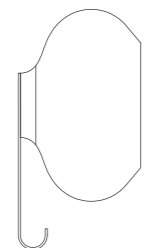

12



22

Cartoccio

Pietro Chiesa 1932



Vaso in vetro naturale (VN), satinato (VS) o stampato (VST). Colori per le versioni in vetro naturale o satinato: bianco (BI), blu (BL), giallo (GI), grigio (G), verde (VE). La lavorazione manuale del vetro rende il vaso unico e diverso da ogni altro.

Vase in clear (VN), satin (VS) or stamped patterned (VST) glass. Colours for the clear or satin glass version: blue (BL), white (BI), yellow (GI), grey (G), green (VE). The hand-crafted production of glass makes each vase unique and different from another.

Vase en verre naturel (VN), satiné (VS) ou imprimé (VST). Couleurs pour les versions en verre naturel ou satiné: bleu (BL), blanc (BI), jaune (GI), gris (G), vert (VE). Le travail à la main du verre rend le vase unique et différent de tous les autres.

Vase aus natürlichem Glas (VN), satiniert (VS) oder dekoriert (VST). Farben für die Versionen aus natürlichem oder satiniertem Glas: weiß (BI), blau (BL), gelb (GI), grau (G) und grün (VE). Das durch Handarbeit hergestellte Glas macht aus jeder Vase ein Einzelstück, jedes anders als das andere.

Jarrón en cristal natural (VN), satinado (VS) o estampado (VST). Colores para la versión de cristal natural o satinado: azul (BL), blanco (BI), amarillo (GI), gris (G), verde (VE). La elaboración manual del vidrio hace que el jarrón sea único y diferente a los demás.

2029/OVS - 2029/OVST	h. 15	
2029/OVN/.. - 2029/OVS/..	h. 15	BI - BL - G - GI - V
2029VS - 2029VST	h. 20	
2029VN/.. - 2029VS/..	h. 20	BI - BL - G - GI - V
2029/1VS - 2029/1VST	h. 30	
2029/1VN/.. - 2029/1VS/..	h. 30	BI - BL - G - GI - V

2029/O..

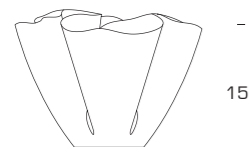

15

2029..

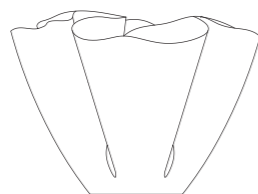

20

2029/1..

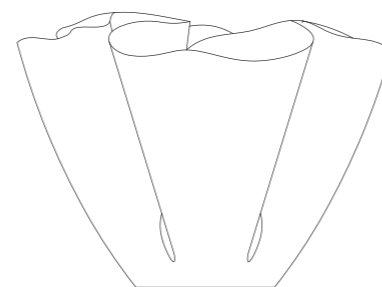

30

Vetro satinato / satin glass / verre satiné / satiniertes Glas / vidrio satinado



2029/OVS



2029VS



2029/1VS



2029/OVS/BI



2029VS/BI



2029/1VS/BI



2029/OVS/BL



2029VS/BL



2029/1VS/BL



2029/OVS/GI



2029VS/GI



2029/1VS/GI



2029/OVS/G



2029VS/G



2029/1VS/G



2029/OVS/V



2029VS/V



2029/1VS/V



2029/OVST



2029VST



2029/1VST

Vetro naturale / natural glass / verre naturel / natürliches Glas / vidrio natural



2029/OVN/BI



2029VN/BI



2029/1VN/BI



2029/OVN/BL



2029VN/BL



2029/1VN/BL



2029/OVN/GI



2029VN/GI



2029/1VN/GI



2029/OVN/G



2029VN/G



2029/1VN/G



2029/OVN/V



2029VN/V



2029/1VN/V

Cartoccio

Pietro Chiesa 1932

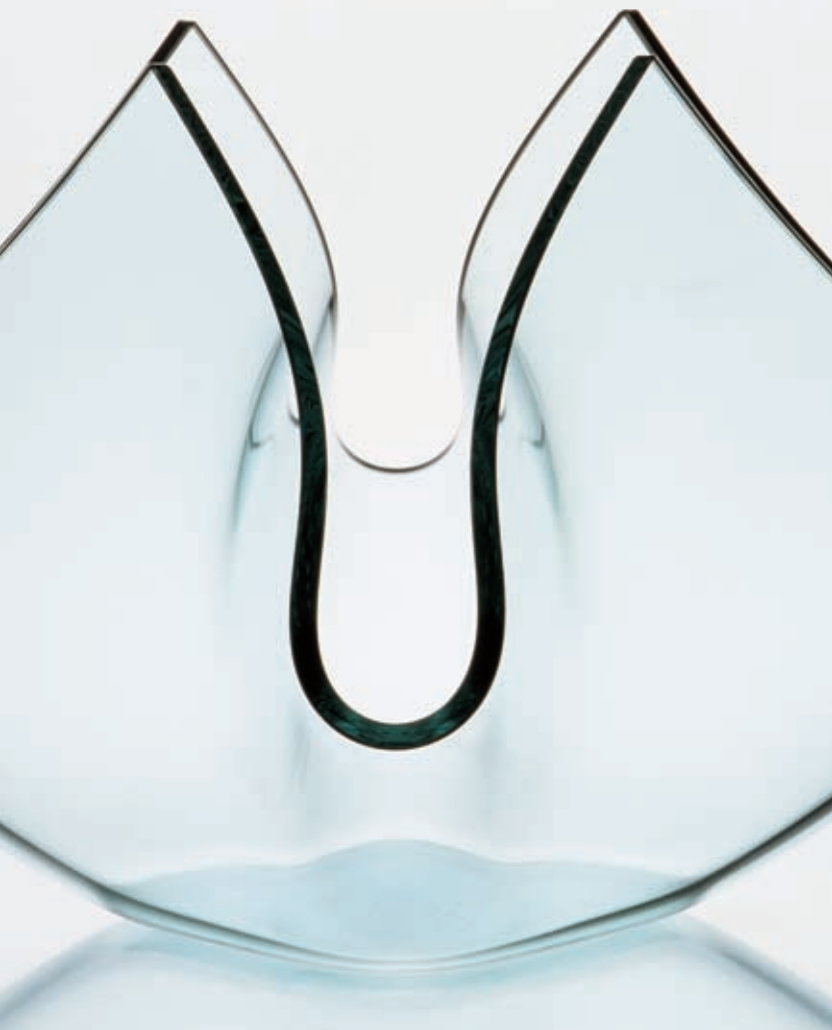

Vaso in vetro trasparente. Vase in clear glass. Vase en verre transparent. Vase aus transparentem Glas. Jarrón de cristal transparente.

2029Q h. 28

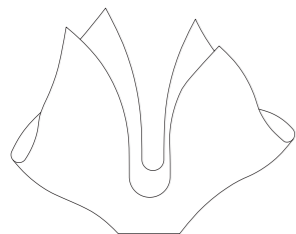

-
28
-